

August 1997

 Complete Data Sheet available via web, Harris' home page: <http://www.semi.harris.com> or via Harris AnswerFAX, see Section 17

**14-Bit/16-Bit, Microprocessor-Compatible, 2-Chip, A/D Converter**

## Features

- 16-Bit/14-Bit Binary Three-State Latched Outputs Plus Polarity and Overrange
- Ideally Suited for Interface to UARTs and Microprocessors
- Conversion on Demand or Continuously
- Guaranteed Zero Reading for 0V Input
- True Polarity at Zero Count for Precise Null Detection
- Single Reference Voltage for True Ratiometric Operation
- Onboard Clock and Reference
- Auto-Zero, Auto-Polarity
- Accuracy Guaranteed to 1 Count
- All Outputs TTL Compatible
- $\pm 4V$  Analog Input Range
- Status Signal Available for External Sync, A/Z in Preamp, Etc.

## Description

The ICL7104, combined with the ICL8052 or ICL8068, forms a member of Harris' high performance A/D converter family. The ICL7104-16, performs the analog switching and digital function for a 16-bit binary A/D converter, with full three-state output, UART handshake capability, and other outputs for easy interfacing. The ICL7014-14 is a 14-bit version. The analog section, as with all Harris' integrating converters, provides fully precise Auto-Zero, Auto-Polarity (including  $\pm 0$  null indication), single reference operation, very high input impedance, true input integration over a constant period for maximum EMI rejection, fully ratiometric operation, over-range indication, and a medium quality built-in reference. The chip pair also offers optional input buffer gain for high sensitivity applications, a built-in clock oscillator, and output signals for providing an external Auto-Zero capability in preconditioning circuitry, synchronizing external multiplexers, etc.

## Ordering Information

PART NUMBER	TEMP. RANGE (°C)	PACKAGE	PKG. NO.
ICL8052CPD	0 to 70	14 Ld PDIP	E14.3
ICL8052CDD	0 to 70	14 Ld CERDIP	F14.3
ICL8052ACPD	0 to 70	14 Ld PDIP	E14.3
ICL8052ACDD	0 to 70	14 Ld CERDIP	F14.3
ICL8068CDD	0 to 70	14 Ld CERDIP	F14.3
ICL8068ACDD	0 to 70	14 Ld CERDIP	F14.3
ICL8068ACJD	0 to 70	14 Ld CERDIP	F14.3
ICL7104-14CPL	0 to 70	40 Ld PDIP	E40.6
ICL7104-16CPL	0 to 70	40 Ld PDIP	E40.6

# ICL8052/ICL7104, ICL8068/ICL7104

## Pinouts

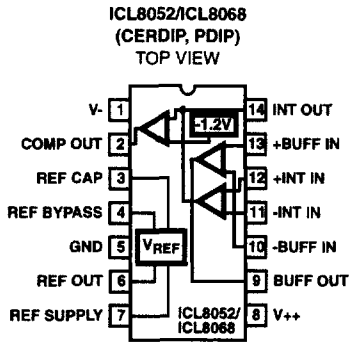

(OUTLINE DWGS DD, JD, PD)

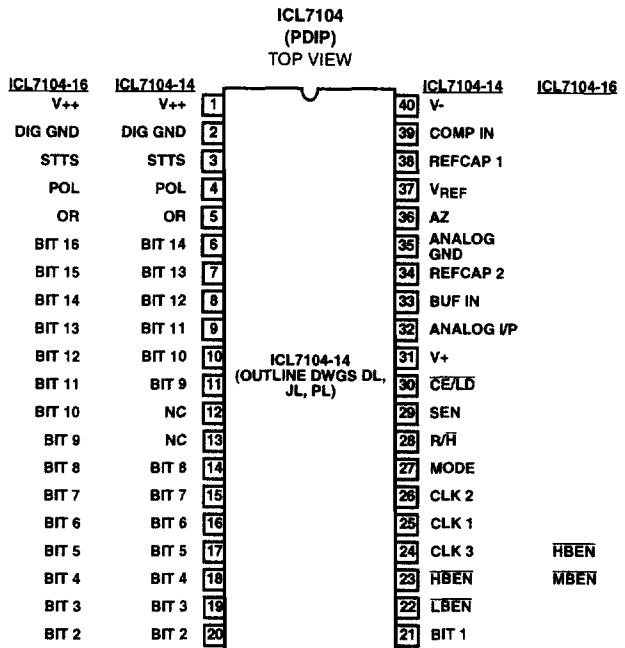

## Functional Block Diagram

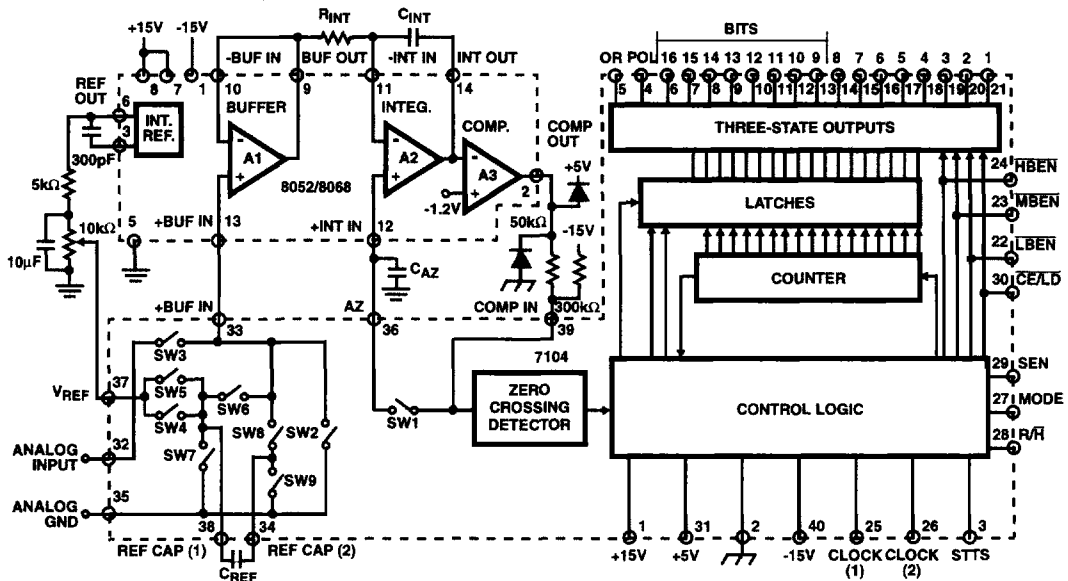

FIGURE 1. ICL8052A (8068A)/ICL7104 16-BIT/14-BIT A/D CONVERTER FUNCTIONAL DIAGRAM

5  
A/D CONVERTERS  
INTEGRATING