



FHP3194

4:1 High-Speed Multiplexer

Features

- 0.1dB gain flatness to 90MHz @ 2V_{pp}
- 0.02%/0.05° differential gain/phase error
- 500MHz large signal -3dB bandwidth at G = 2
- 2200V/μs slew rate
- 75mA output current (easily drives two video loads)
- 70dB channel-to-channel isolation
- 13mA supply current
- 3.5mA supply current in disable mode
- 2.5mA supply current in shutdown mode
- Fully specified at ±5V supplies
- Lead-free SOIC-14 and TSSOP-14 packages

Applications

- Video switchers and routers
- Multiple input HDTV switching
- Picture-in-picture video switch
- Multi-channel ADC driver

Description

The FHP3194 is a 4:1 analog multiplexer designed for high-speed video applications. The output amplifier is a high-speed current feedback amplifier that offers stellar large signal performance of 500MHz -3dB bandwidth and 90MHz 0.1dB bandwidth. The gain of the output amplifier is selectable through two external resistors (R_f and R_g), allowing further design flexibility. The 2V_{pp} bandwidth performance and 2200V/μs slew rate exceed the requirements of high-definition television (HDTV) and other multimedia applications. The output amplifier also provides ample output current to drive multiple video loads.

Two address bits (A0 and A1) are used to select one of the four inputs. The FHP3194 offers better than 70dB channel isolation.

The FHP3194 offers both shutdown and disable capability. During shutdown, the FHP3194 consumes only 2.5mA of supply current. During disable mode, only the output amplifier is disabled, reducing output glitches and allowing for multiplexer expansion.

Functional Block Diagram

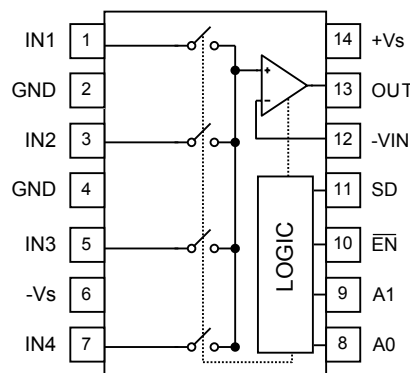

Ordering Information

Part Number	Package	Pb-Free	Operating Temperature Range	Packaging Method
FHP3194IM14X	SOIC-14	Yes	-40°C to +85°C	Reel
FHP3194IMTC14X	TSSOP-14	Yes	-40°C to +85°C	Reel

Moisture sensitivity level for all parts is MSL-1.

Pin Configuration

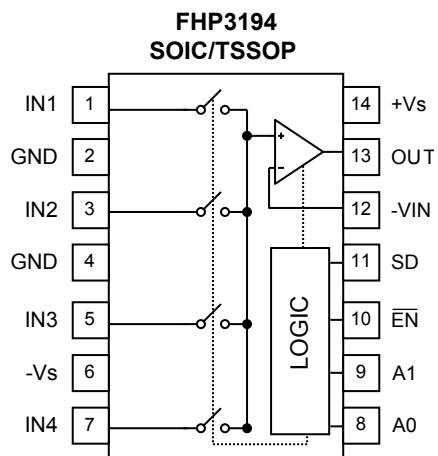

Pin Assignments

Pin#	Pin Name	Description
1	IN1	Input, channel 1
2	GND	Must be connected to ground
3	IN2	Input, channel 2
4	GND	Must be connected to ground
5	IN3	Input, channel 3
6	-Vs	Negative supply
7	IN4	Input, channel 4
8	A0	Logic input A0
9	A1	Logic input A1
10	\overline{EN}	Enable pin, "1" = Disable, "0" = Enable; Enabled when left floating
11	SD	Shutdown pin, "1" = Shutdown, "0" = Active; Active when left floating
12	-VIN	Inverting Input of output amplifier
13	OUT	Output
14	+Vs	Positive supply

Truth Table

A0	A1	\overline{EN}	SD	OUT
1	1	0	0	CH4
0	1	0	0	CH3
1	0	0	0	CH2
0	0	0	0	CH1
X	X	1	0	Disable
X	X	X	1	Shutdown

Absolute Maximum Ratings

The “Absolute Maximum Ratings” are those values beyond which the safety of the device cannot be guaranteed. The device should not be operated at these limits. The parametric values defined in the Electrical Characteristics tables are not guaranteed at the absolute maximum ratings. The “Recommended Operating Conditions” table defines the conditions for actual device operation.

Parameter	Min.	Max.	Unit
Supply Voltage	0	12.6	V
Input Voltage Range	$-V_s - 0.5V$	$+V_s + 0.5V$	V

Reliability Information

Parameter	Min.	Typ.	Max.	Unit
Junction Temperature			150	°C
Storage Temperature Range	-65		150	°C
Lead Temperature (Soldering, 10s)			300	°C
Package Thermal Resistance				
14-Lead TSSOP ¹		113		°C/W
14-Lead SOIC ¹		125		°C/W

Notes:

1. Package thermal resistance (θ_{JA}), JEDEC standard, multi-layer test boards, still air.

ESD Protection

Product	SOIC-14	TSSOP-14
Human Body Model (HBM)	3.5kV	3kV
Charged Device Model (CDM)	2kV	2kV

Recommended Operating Conditions

Parameter	Min.	Typ.	Max.	Unit
Operating Temperature Range	-40		+85	°C
Supply Voltage Range	5		12	V

Electrical Characteristics at $\pm 5V$

$T_A = 25^\circ C$, $V_S = \pm 5V$, $R_f = 475\Omega$, $R_L = 150\Omega$, $G = 2$; unless otherwise noted.

Symbol	Parameter	Conditions	Min.	Typ.	Max.	Units
Frequency Domain Response						
UGBW	-3dB Bandwidth	$G = +1$, $R_f = 1.5k\Omega$ $V_{OUT} = 0.2V_{pp}$		1200		MHz
BW _{SS}	-3dB Bandwidth	$G = +2$, $V_{OUT} = 0.2V_{pp}$		800		MHz
BW _{LS}	Full Power Bandwidth	$G = +2$, $V_{OUT} = 2V_{pp}$		500		MHz
	0.1dB Gain Flatness	$G = +2$, $V_{OUT} = 0.2V_{pp}$		200		MHz
	0.1dB Gain Flatness	$G = +2$, $V_{OUT} = 2V_{pp}$		90		MHz
Time Domain Response						
t_R, t_F	Rise and Fall Time	$V_{OUT} = 2V$ step; (10% to 90%)		1		ns
t_S	Settling Time to 0.1%	$V_{OUT} = 2V$ step		15		ns
OS	Overshoot	$V_{OUT} = 0.2V$ step		4		%
SR	Slew Rate	4V step		2200		V/ μs
Distortion / Noise Response						
HD2	2nd Harmonic Distortion	$2V_{pp}$, 5MHz, worst channel		-68		dBc
HD3	3rd Harmonic Distortion	$2V_{pp}$, 5MHz, worst channel		-89		dBc
THD	Total Harmonic Distortion	$2V_{pp}$, 5MHz, worst channel		-67		dB
DG	Differential Gain	NTSC (3.58MHz), DC-coupled		0.02		%
DP	Differential Phase	NTSC (3.58MHz), DC-coupled		0.05		$^\circ$
e_n	Input Voltage Noise	> 1MHz		7		nV/ \sqrt{Hz}
i_{n+}	Input Current Noise (+)	> 1MHz		22		pA/Hz
i_{n-}	Input Current Noise (-)	> 1MHz		16		pA/Hz
X _{TALK}	All Hostile Crosstalk	Channel-to-channel 5MHz/ 30MHz, worst CH combination		-68/-53		dB
DC Performance						
V_{IO}	Input Offset Voltage ⁽¹⁾		-9	1	+9	mV
dV_{IO}	Average Drift			8.5		$\mu V/^\circ C$
V_{IOM}	Input Offset Voltage Matching ⁽¹⁾	Channel-to-channel	-5	0.8	5	mV
I_{bn}	Input Bias Current Non-inverting ⁽¹⁾	Pins 1,3,5,7	-30	4	30	μA
dI_{bn}	Average Drift			25		nA/ $^\circ C$
I_{bi}	Input Bias Current Inverting ⁽¹⁾	Pin 12	-35	13	35	μA
dI_{bni}	Average Drift			20		nA/ $^\circ C$
GM	Gain Matching	Channel-to-channel		0.02		%
PSRR	Power Supply Rejection Ratio ⁽¹⁾	DC	54	65		dB
I_S	Supply Current ⁽¹⁾			13	18	mA
I_{EN}	Disable Supply Current ⁽¹⁾	Disable mode		3.5	6	mA
I_{SD}	Shutdown Supply Current ⁽¹⁾	Shutdown mode		2.5	5	mA
Switching Characteristics						
T_S	Switching Time 50% Logic to:	Channel-to-channel				
	90% output (10% output settling) ⁽²⁾	IN1, IN3 = +0.5V; IN2, IN4 = -0.5V		25		ns
	99% output (1% output settling) ⁽²⁾	IN1, IN3 = +0.5V; IN2, IN4 = -0.5V		40		ns
V_{SW}	Channel Switch. Trans. (Glitch)	All inputs grounded		375		mV _{pp}

Notes:

1. 100% tested at 25°C

Electrical Characteristics at $\pm 5V$ (Continued)

$T_A = 25^\circ\text{C}$, $V_S = \pm 5V$, $R_f = 475\Omega$, $R_L = 150\Omega$, and $G = 2$ unless otherwise noted.

Symbol	Parameter	Conditions	Min.	Typ.	Max.	Unit
Digital Inputs						
V_{IH}	Logic-High Threshold	A0, A1, \overline{EN} , and SD pins	2.0			V
V_{IL}	Logic-Low Threshold	A0, A1, \overline{EN} , and SD pins			0.8	V
I_{IH}	Logic Pin Input Current High	A0, A1, \overline{EN} , and SD pins Logic input = 0V		22		μA
I_{IL}	Logic Pin Input Current Low	A0, A1, \overline{EN} , and SD pins Logic input = 0V		0		μA
Disable Characteristics						
\overline{EN}_{ISO}	Disable Isolation	5MHz/30MHz, worst comb.		-76/-61		dB
SD_{ISO}	Shutdown Isolation	5MHz/30MHz, worst comb.		-76/-61		dB
CH_{ISO}	CH-to-CH Isolation ⁽³⁾	5MHz/30MHz, worst comb.		-70/-55		dB
\overline{EN}_{TON}	Turn-on time (Disable to ON)	$V_{IN} = 500\text{mV}$		30		ns
\overline{EN}_{TOFF}	Turn-off time (ON to Disable)	$V_{IN} = 500\text{mV}$		65		ns
SD_{TON}	Turn-on time (Shutdown to ON)	$V_{IN} = 500\text{mV}$		32		ns
SD_{TOFF}	Turn-off time (ON to Shutdown)	$V_{IN} = 500\text{mV}$		66		ns
Input Characteristics						
R_{IN}	Input Resistance			188		k Ω
C_{IN}	Input Capacitance			1.7		pF
CMIR	Input Common Mode V Range			± 3.1		V
CMRR	Common Mode Rejection Ratio ⁽¹⁾	DC	50	60		dB
Output Characteristics						
V_{OUT}	Output Voltage Swing	$R_L = 2\text{k}\Omega$		± 4.0		V
		$R_L = 150\Omega^{(1)}$	± 3.2	± 3.8		V
I_{OUT}	Linear Output Current	$V_{IN} = 0$		± 75		mA
I_{SC}	Short-Circuit Output Current	$V_{OUT} = \text{GND}$, $R_L = 0\Omega$		± 100		mA
R_{OUT}	Output Resistance	Enabled		0.1		Ω
		Disabled		1		k Ω
C_{OUT}	Output Capacitance			3.7		pF

Notes:

1. 100% tested at 25°C

2. SD and \overline{EN} pins are grounded. IN1 and IN3 = +0.5V, IN2 and IN4 = -0.5V, see truth table to properly set A0 and A1 based on the channels driven. Switching time is the transition time from 50% of A0 or A1 input value (+2.5V) to the time at which the switched channel is at 90% (or 99%) of its final value.

3. Driving one channel and looking at worst case value from remaining channels.

Typical Performance Characteristics

$T_A = 25^\circ\text{C}$, $V_S = \pm 5\text{V}$, $R_f = 475\Omega$, $R_L = 150\Omega$, and $G = 2$ unless otherwise noted.

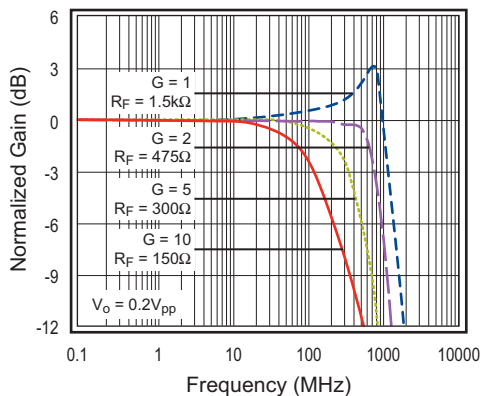

Figure 1. Non-Inverting Freq. Response

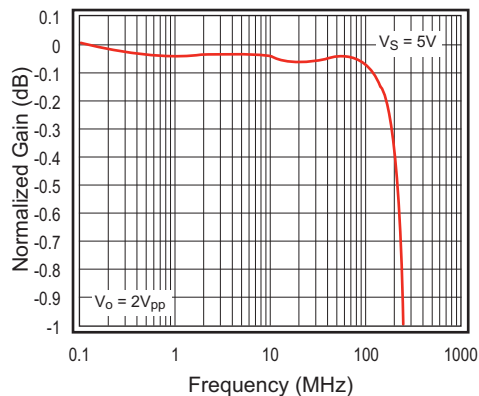

Figure 2. Gain Flatness vs. Frequency

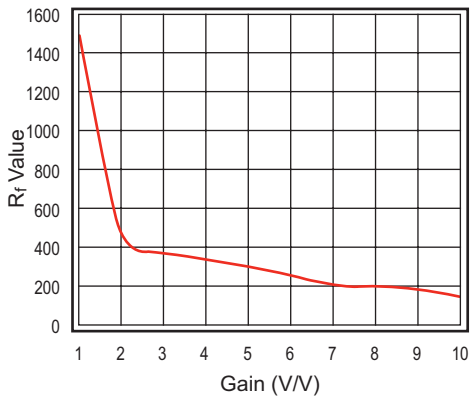

Figure 3. Recommended R_f vs. Gain

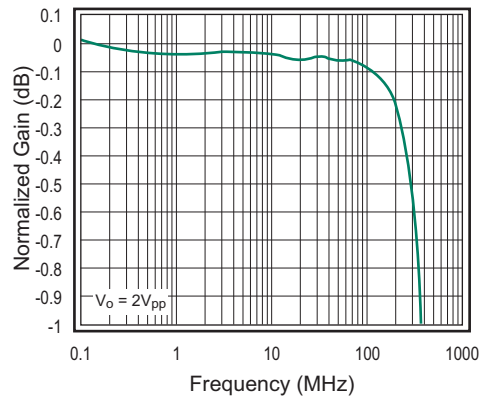

Figure 4. Gain Flatness vs. Frequency

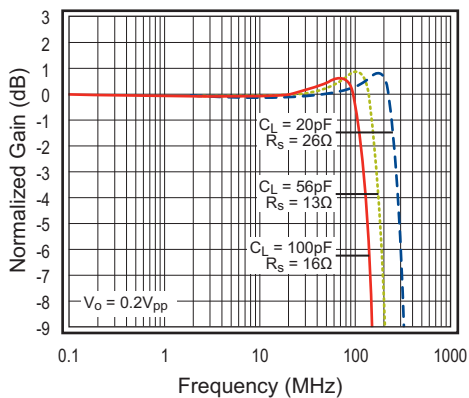

Figure 5. Frequency Response vs. C_L

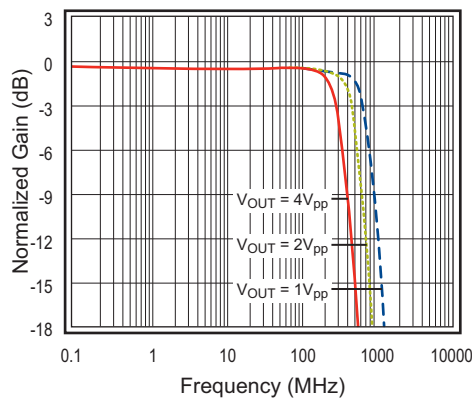

Figure 6. Frequency Response vs. V_{OUT}

Typical Performance Characteristics

$T_A = 25^\circ\text{C}$, $V_S = \pm 5\text{V}$, $R_f = 475\Omega$, $R_L = 150\Omega$, and $G = 2$ unless otherwise noted.

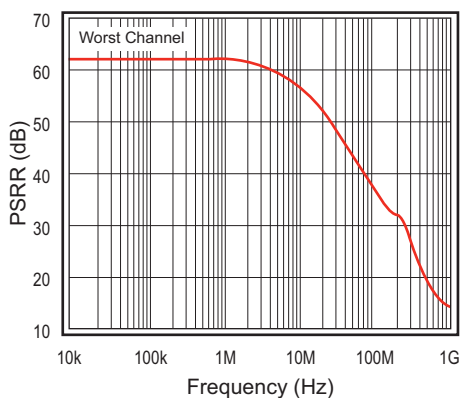

Figure 7. PSRR vs. Frequency

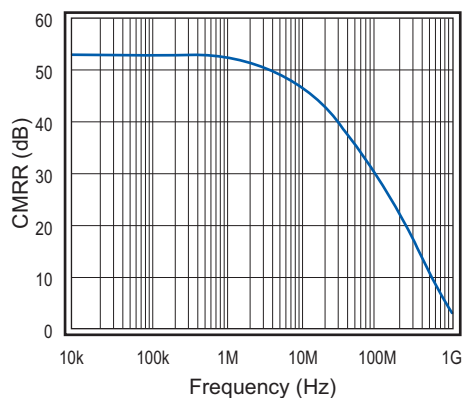

Figure 8. CMRR vs. Frequency

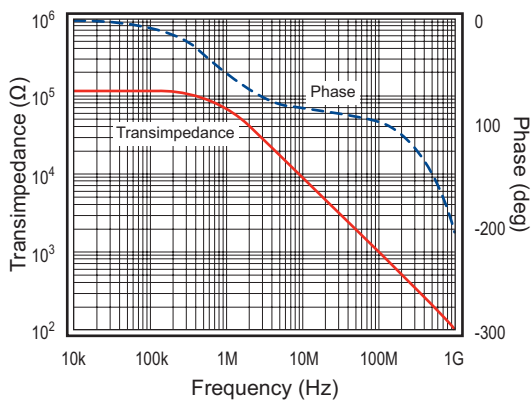

Figure 9. Open Loop Transimpedance Gain and Phase

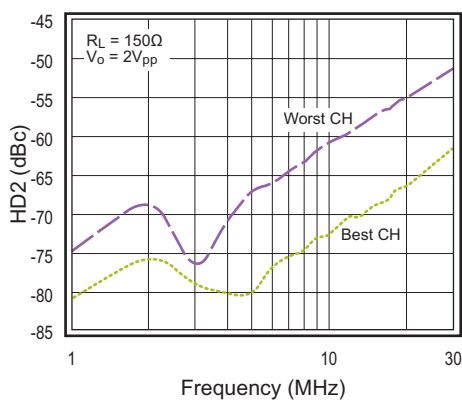

Figure 10. HD2 vs. Frequency

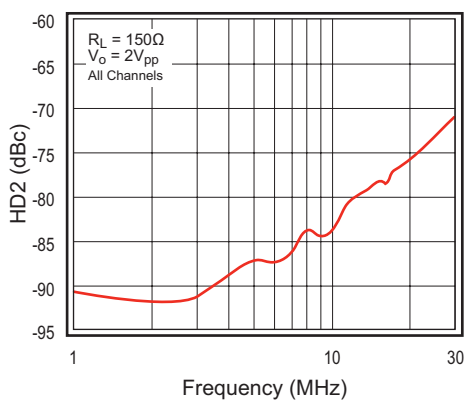

Figure 11. HD3 vs. Frequency

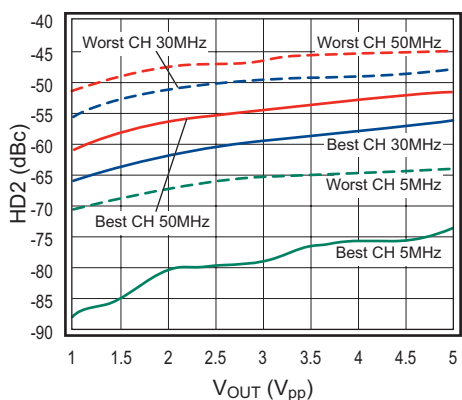

Figure 12. HD2 vs. V_{OUT}

Typical Performance Characteristics

$T_A = 25^\circ\text{C}$, $V_S = \pm 5\text{V}$, $R_f = 475\Omega$, $R_L = 150\Omega$, and $G = 2$ unless otherwise noted.

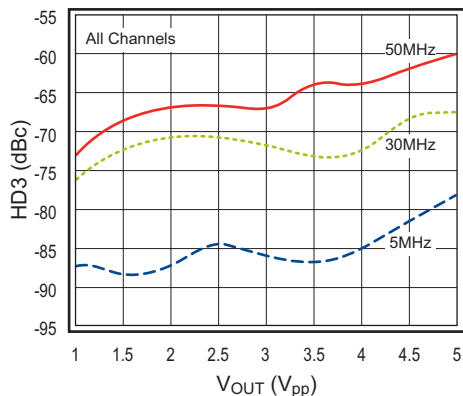

Figure 13. HD3 vs. V_{OUT}

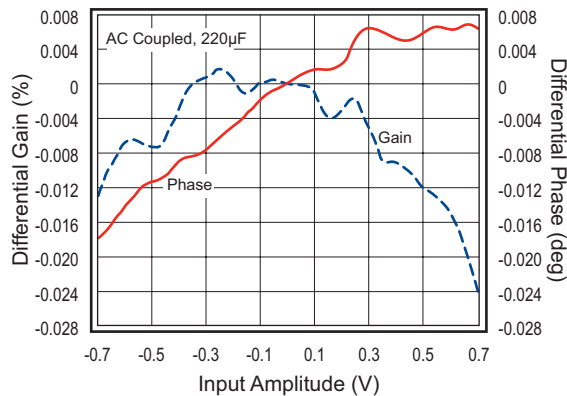

Figure 14. Differential Gain and Phase

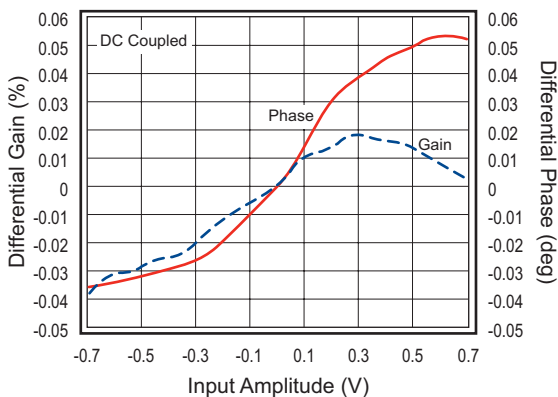

Figure 15. Differential Gain and Phase

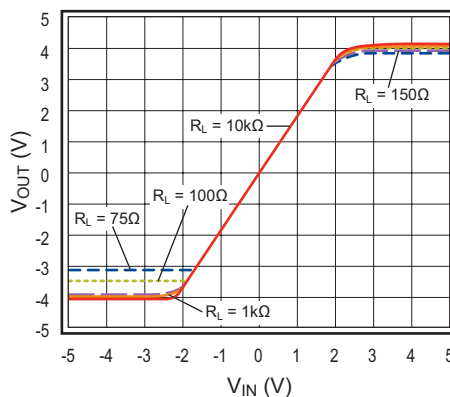

Figure 16. Output Swing vs. R_L

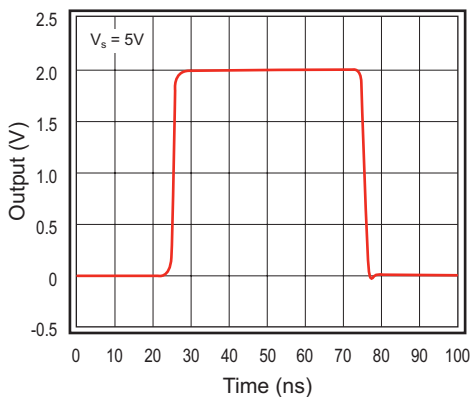

Figure 17. Pulse Response

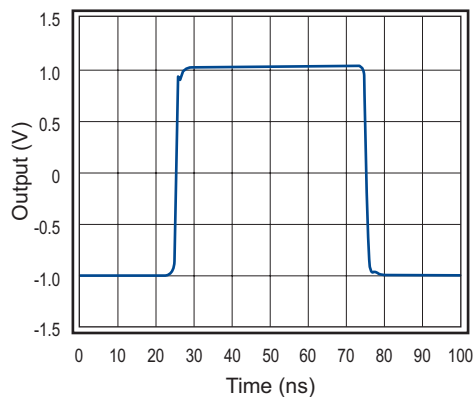

Figure 18. Pulse Response

Typical Performance Characteristics

$T_A = 25^\circ\text{C}$, $V_S = \pm 5\text{V}$, $R_f = 475\Omega$, $R_L = 150\Omega$, and $G = 2$ unless otherwise noted.

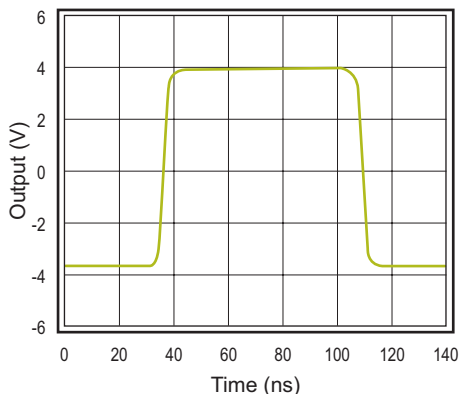

Figure 19. Pulse Response

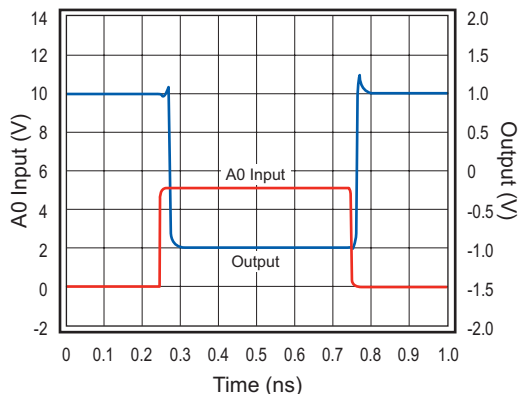

Figure 20. Channel Switching Time

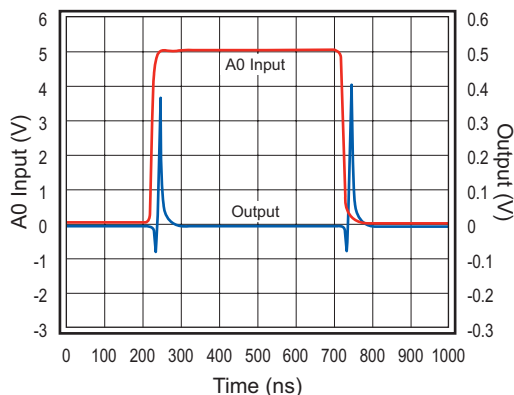

Figure 21. A0 Switching Glitch

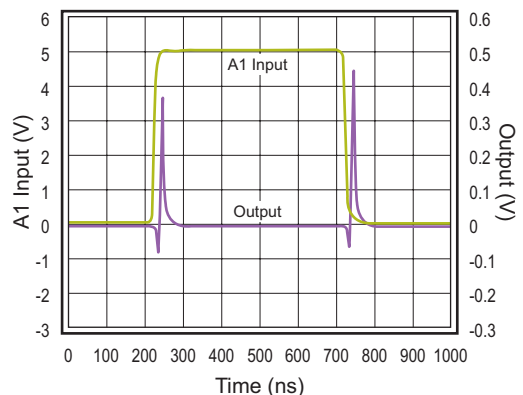

Figure 22. A1 Switching Glitch

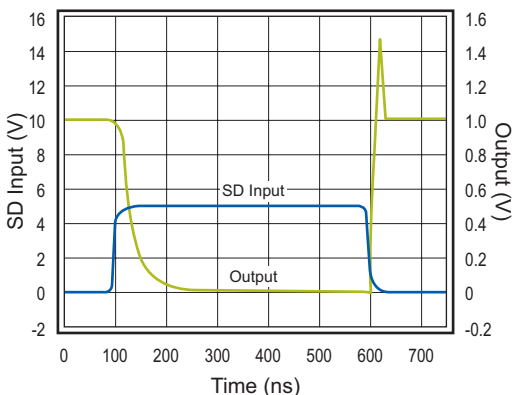

Figure 23. Shutdown Switching Time

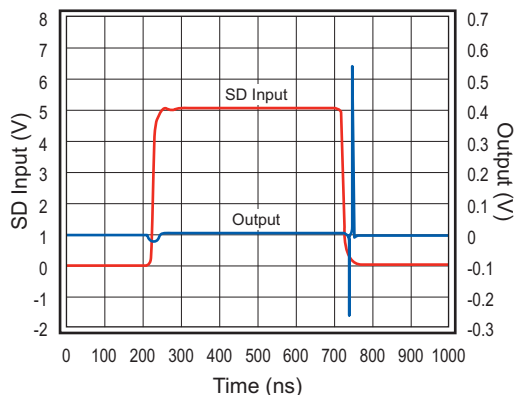

Figure 24. Shutdown Switching Glitch

Typical Performance Characteristics

$T_A = 25^\circ\text{C}$, $V_S = \pm 5\text{V}$, $R_f = 475\Omega$, $R_L = 150\Omega$, and $G = 2$ unless otherwise noted.

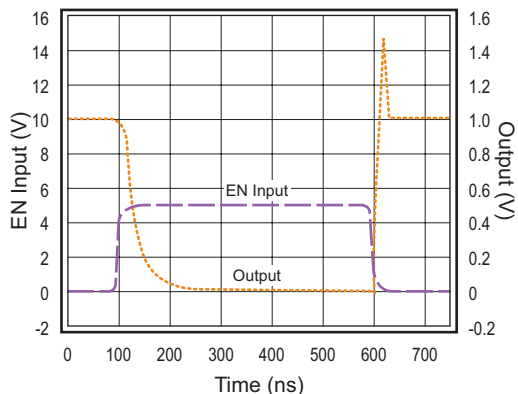

Figure 25. Enable Switching Time

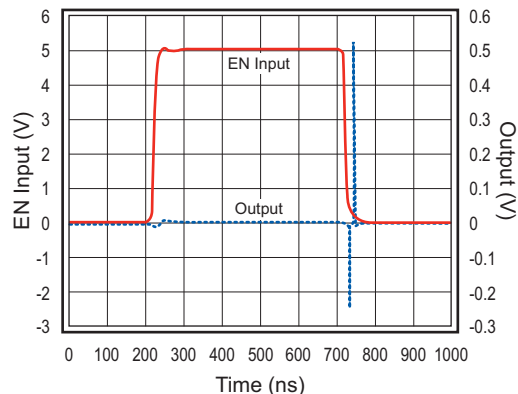

Figure 26. Enable Switching Glitch

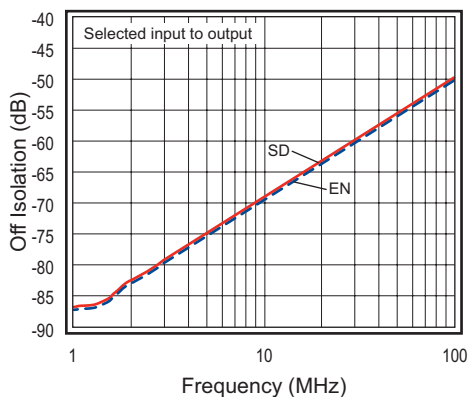

Figure 27. Off Isolation vs. Frequency

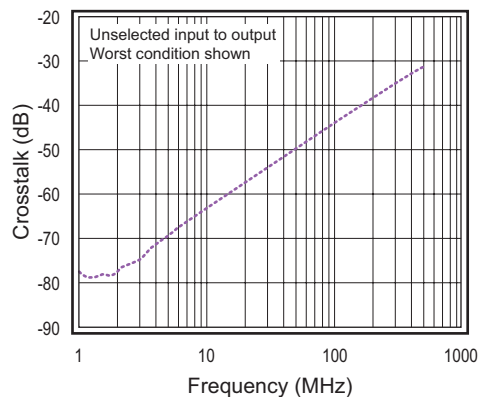

Figure 28. Crosstalk vs. Frequency

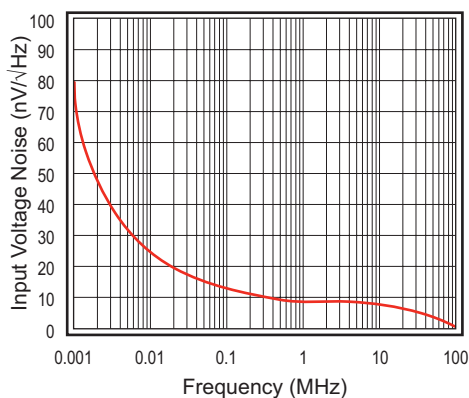

Figure 29. Input Voltage Noise

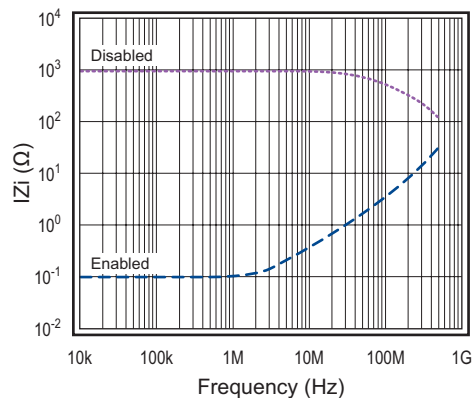

Figure 30. Closed-Loop Output Impedance

Application Information

Circuit Diagrams

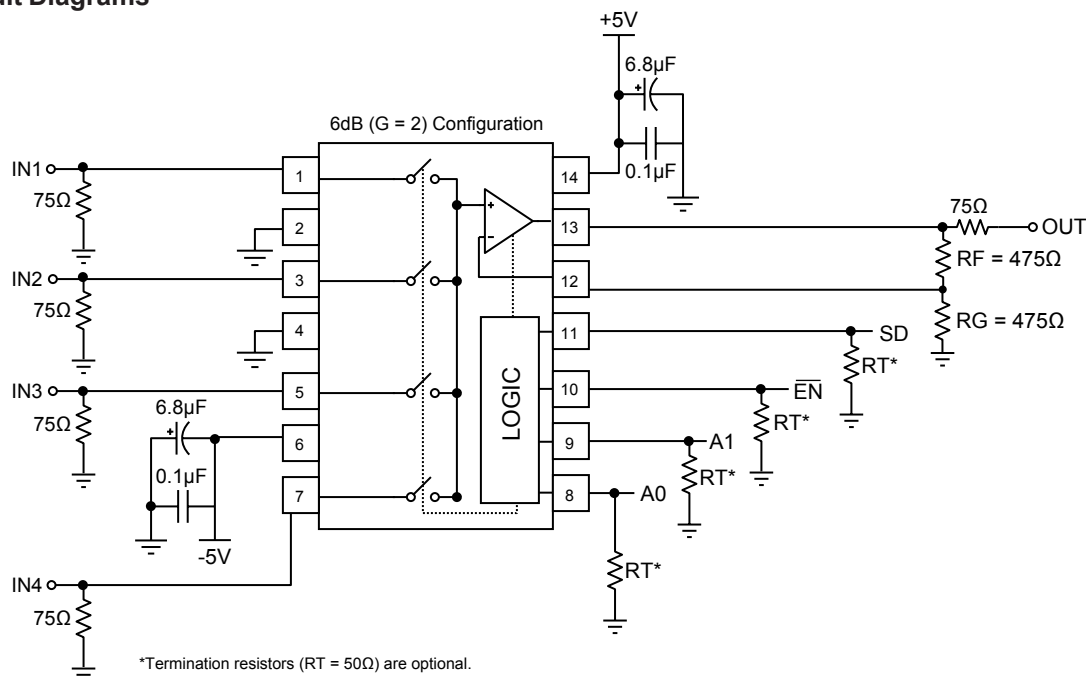

Figure 31. Typical Application Circuit 6dB Gain (G = 2)

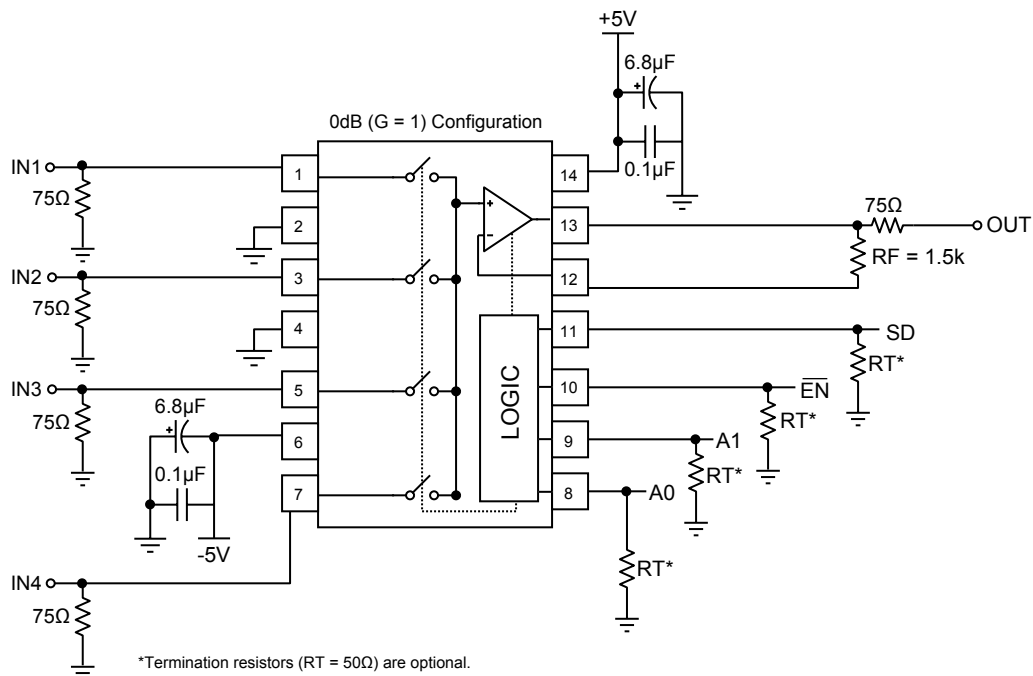

Figure 32. Typical Application Circuit 0dB Gain (G = 1)

Application Information

General Description

The FHP3194 4:1 multiplexer has four analog switches that drive the positive input of a high-speed current feedback amplifier. It is designed so that only one channel is on at a time. Tie unused inputs to ground.

Figures 31 and 32 show typical application circuits for the FHP3194 in 6dB ($G = 2$) and 0dB ($G = 1$) configurations.

R_f and R_g Selection

The output of the FHP3194 is a current feedback amplifier. The gain of this amplifier is set by two external resistors: R_f and R_g . The frequency response and closed-loop bandwidth of the current feedback amplifier are highly dependant on the value of R_f . For a gain of two, use $R_f = 475\Omega$. For other gains, refer to the R_f vs. GAIN plot in Figure 3. In general, a lower R_f peaks the frequency response and increases bandwidth, while a higher R_f will decrease bandwidth and roll off the frequency response. A feedback resistor is required for unity gain ($G = 1$); the recommended value is 1.5k Ω .

A0, A1

The A0 and A1 logic pins are TTL/CMOS compatible and are used to select which of the four inputs connects to the output. Refer to the TRUTH TABLE on page 2 for more information. Channel 1 is selected if both pins are left floating.

\overline{EN} , SD

The FHP3194 offers both shutdown and disable capability. The \overline{EN} (enable) pin is active low. During disable mode ($\overline{EN} = 1$), only the output amplifier is disabled, reducing output glitches and allowing for multiplexer expansion. The FHP3194 is enabled when the \overline{EN} pin is left floating or grounded.

The SD (shutdown) pin is active high. During shutdown ($SD = 1$), the FHP3194 consumes only 2.5mA of supply current. The FHP3194 is enabled when the SD pin is left floating or grounded.

Supply Voltage

The FHP3194 operates from a single supply of 5V to 12V or dual supplies of $\pm 2.5V$ to $\pm 6.0V$. For low supply voltage operation, ensure that the common mode input voltage range (CMIR) or output voltage range (V_o) are not exceeded. Exceeding the CMIR or V_o range puts the FHP3194 into an overdrive condition. For example, the typical CMIR for the FHP3194 is $\pm 3.1V$ at $\pm 5V$ supply, which means 1.9V of headroom is required from each supply.

At a single 5V supply, the CMIR becomes 1.9V to 3.1V. The same theory can be applied to the V_{OUT} range.

Driving Video

The FHP3194 is designed to drive high-speed video. 90MHz 0.1dB bandwidth at $2V_{pp}$ output, 0.02°/0.05% differential gain/phase, and $\pm 75mA$ output current make the FHP3194 suitable for driving standard-definition, high-definition, or PC graphics video.

Driving Video with a Single 5V Supply

The FHP3194 drives video signals from a single 5V supply at $G = 1$ only. At higher gains, the CMIR and V_o range is not suitable for passing video without clipping the signal.

Driving Capacitive Loads

The FREQUENCY RESPONSE VS. C_L plot in Figure 5, illustrates the response of the FHP3194. A small series resistance (R_s) at the output of the amplifier, illustrated in Figure 33, improves stability and settling performance. R_s values in the FREQUENCY RESPONSE VS. C_L plot were chosen to achieve maximum bandwidth with less than 1dB of peaking. For maximum flatness, use a larger R_s .

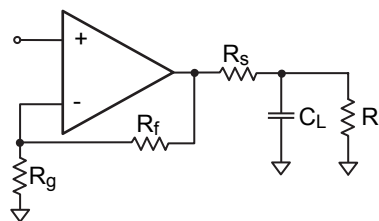

Figure 33. Typical Topology for Driving Capacitive Loads

Power Dissipation

The maximum internal power dissipation allowed is directly related to the maximum junction temperature. If the maximum junction temperature exceeds 150°C for an extended time, device failure may occur. The FHP3194 is short-circuit protected; however, this may not guarantee that the maximum junction temperature ($+150^\circ C$) is not exceeded under all conditions. RMS power dissipation can be calculated using the following equation:

$$\text{Power Dissipation} = I_s * (V_{S+} - V_{S-}) + (V_{S+} - V_{O(RMS)}) * I_{OUT(RMS)}$$

where I_s is the supply current, V_{S+} is the positive supply pin voltage, V_{S-} is the negative supply pin voltage, $V_{O(RMS)}$ is the RMS output voltage, and $I_{OUT(RMS)}$ is the RMS output current delivered to the load. Follow the maximum power derating curves shown in Figure 34 to ensure proper operation.

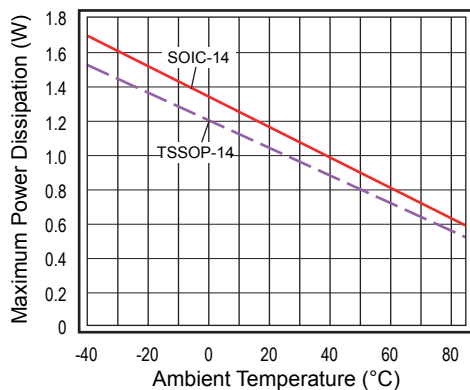

Figure 34. Maximum Power Derating

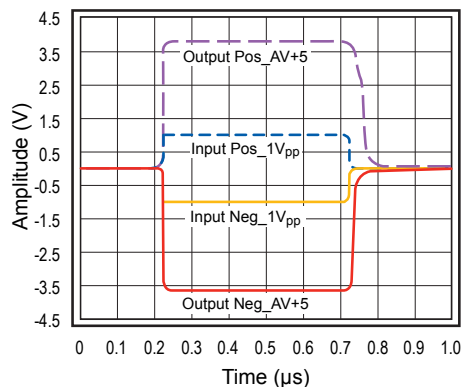

Figure 35. Overdrive Recovery

Overdrive Recovery

For an amplifier, an overdrive condition occurs when the output and/or input ranges are exceeded. The recovery time varies based on whether the input or output is overdriven and by how much the ranges are exceeded. The FHP3194 typically recovers in less than 75ns from an overdrive condition. Figure 35 shows the FHP3194 in an overdriven condition.

Layout Considerations

General layout and supply bypassing play major roles in high-frequency performance. Fairchild has evaluation boards to use as a guide for high-frequency layout and as aid in device testing and characterization. Follow the guidelines below as a basis for high-frequency layout:

- Include 6.8µF and 0.1µF ceramic capacitors.
- Place the 6.8µF capacitor within 0.75 inches of the power pin.
- Place the 0.1µF capacitor within 0.1 inches of the power pin.
- Remove the ground plane under and around the part, especially near the input and output pins and under R_f and R_g , to reduce parasitic capacitance.
- Minimize all trace lengths to reduce series inductances.

For current feedback amplifiers, stray capacitance from the inverting input (pin 12) to ground or to the output (pin 13) increases peaking in the AC response. For optimum performance, place R_f and R_g as close to the FHP3194 as possible. Small-size surface-mount resistors are recommended.

Avoid the use of vias near the device; vias add unwanted inductance.

If traces of greater than one inch are required, use stripline or microstrip techniques designed with characteristic impedances of 50Ω or 75Ω that are properly terminated with impedance-matching elements at each end.

Refer to the evaluation board layouts for more information.

Evaluation Board Information

The following evaluation boards are available to aid in the testing and layout of these devices:

Evaluation Board	Products
KEB022	FHP3194IM14X
KEB025	FHP3194IMTC14X

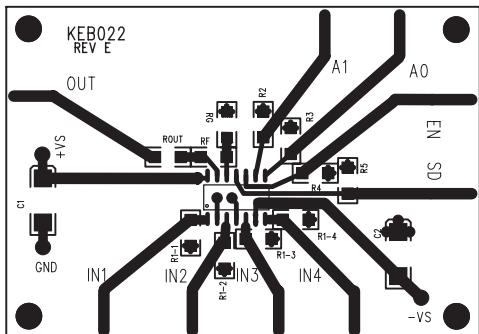

Figure 36. KEB022 Top-Side

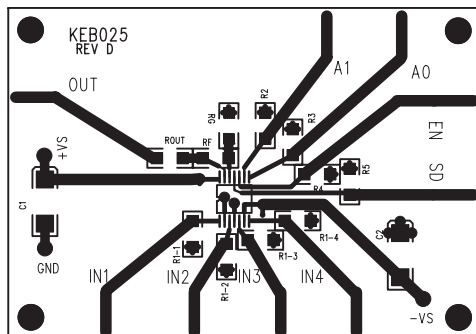

Figure 38. KEB025 Top-Side

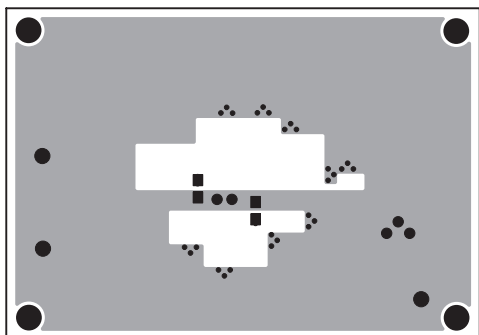

Figure 37. KEB022 Bottom-Side

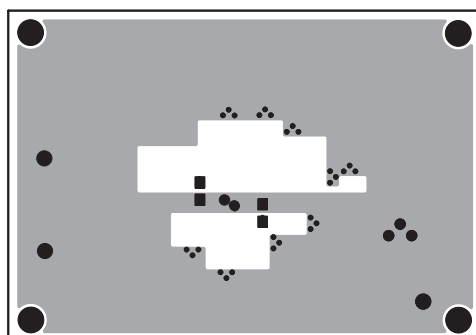
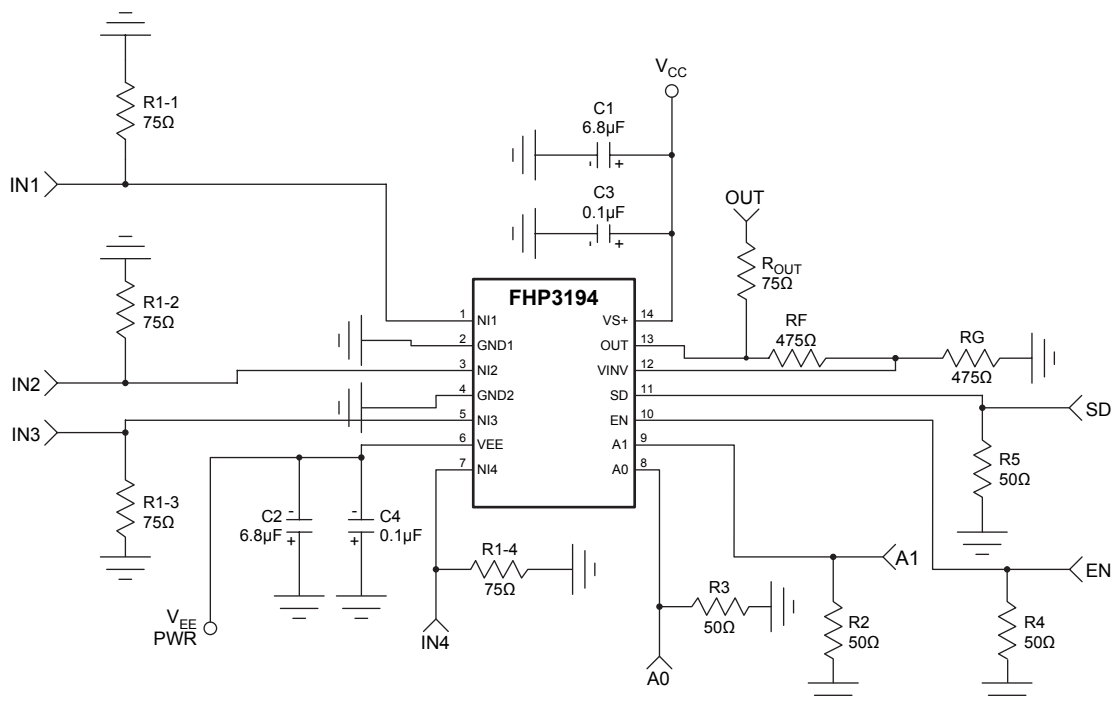

Figure 39. KEB025 Bottom-Side



*Choose R1-1, R1-2, R1-3, R1-4, and ROUT for proper impedance matching. R2, R3, R4, and R5 are optional.

Figure 40. FHP3194 Schematic Diagram

Mechanical Dimensions

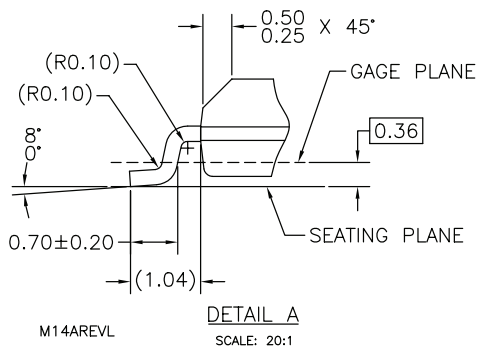
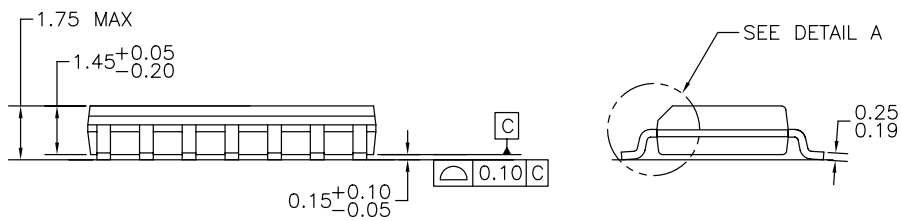
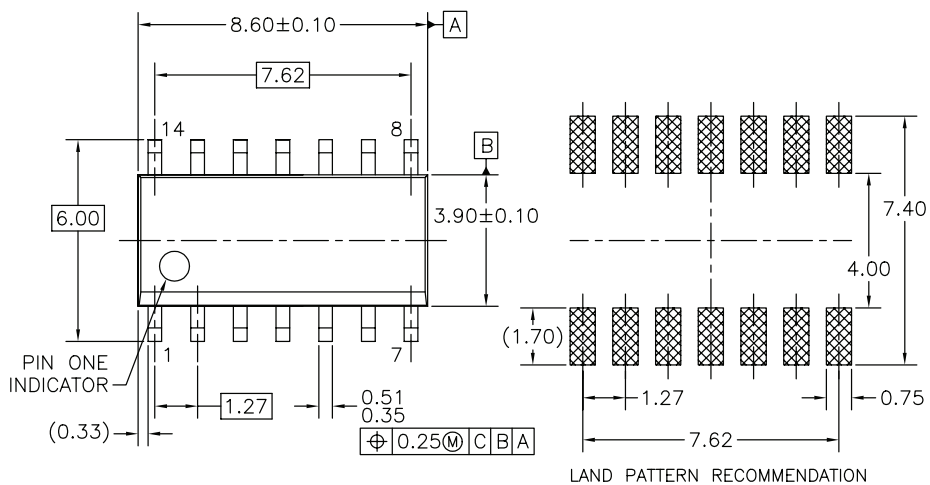

- NOTES: UNLESS OTHERWISE SPECIFIED
- A) THIS PACKAGE CONFORMS TO JEDEC MS-012, VARIATION AB, ISSUE C, DATED MAY 1990.
 - B) ALL DIMENSIONS ARE IN MILLIMETERS.
 - C) DIMENSIONS DO NOT INCLUDE MOLD FLASH OR BURRS.

M14AREVL
 DETAIL A
 SCALE: 20:1

Figure 41. SOIC-14 Package

Mechanical Dimensions

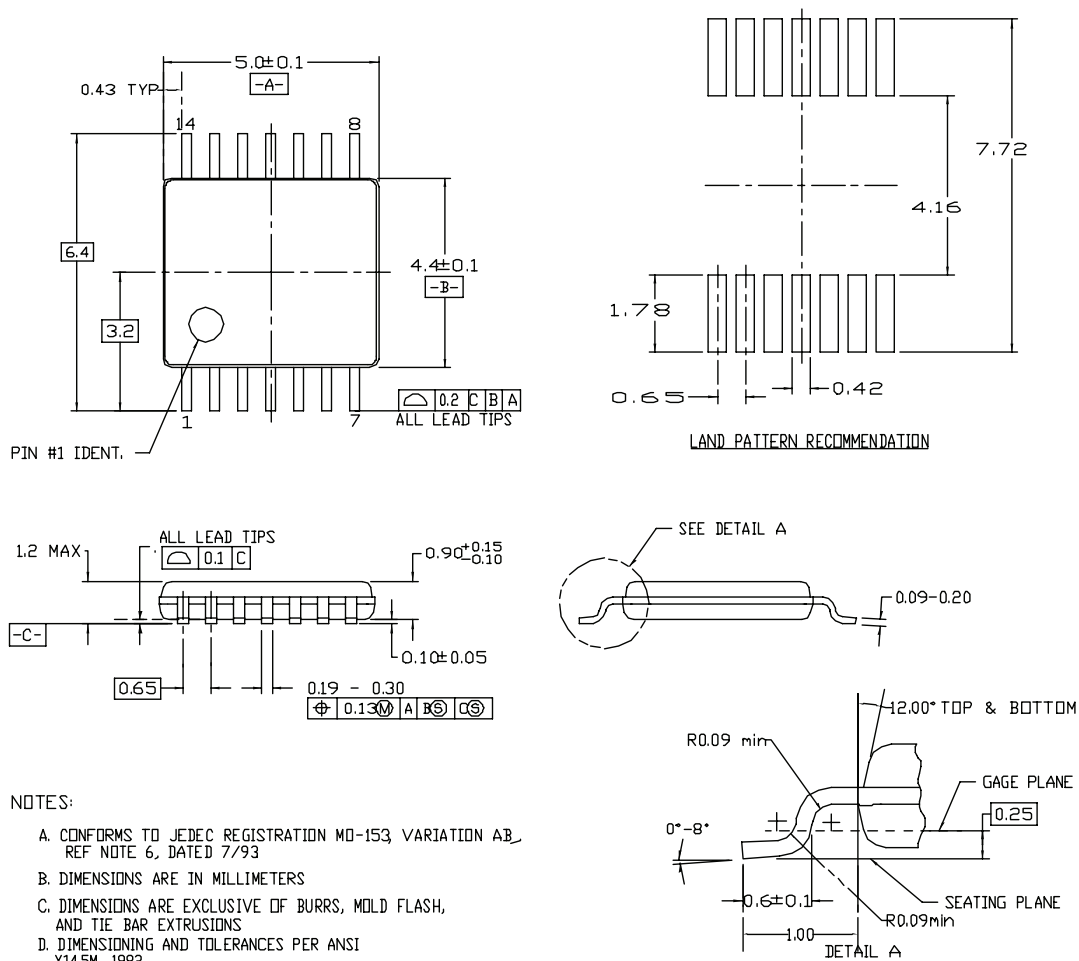

Figure 42. TSSOP-14 Package

TRADEMARKS

The following are registered and unregistered trademarks Fairchild Semiconductor owns or is authorized to use and is not intended to be an exhaustive list of all such trademarks.

ACE ^x ™	FACT Quiet Series™	OCX™	SILENT SWITCHER®	UniFET™
ActiveArray™	GlobalOptoisolator™	OCXPro™	SMART START™	UltraFET®
Bottomless™	GTO™	OPTOLOGIC®	SPM™	VCX™
Build it Now™	HiSeC™	OPTOPLANAR™	Stealth™	Wire™
CoolFET™	I ² C™	PACMAN™	SuperFET™	
CROSSVOLT™	i-Lo™	POP™	SuperSOT™_3	
DOME™	ImpliedDisconnect™	Power247™	SuperSOT™_6	
EcoSPARK™	IntelliMAX™	PowerEdge™	SuperSOT™_8	
E ² CMOS™	ISOPLANAR™	PowerSaver™	SyncFET™	
EnSigna™	LittleFET™	PowerTrench®	TCM™	
FACT™	MICROCOUPLER™	QFET®	TinyBoost™	
FAST®	MicroFET™	QS™	TinyBuck™	
FAST _r ™	MicroPak™	QT Optoelectronics™	TinyPWM™	
FPS™	MICROWIRE™	Quiet Series™	TinyPower™	
FRFET™	MSX™	RapidConfigure™	TinyLogic®	
	MSXPro™	RapidConnect™	TINYOPTO™	
Across the board. Around the world.™		μSerDes™	TruTranslation™	
The Power Franchise®		ScalarPump™	UHC™	
Programmable Active Droop™				

DISCLAIMER

FAIRCHILD SEMICONDUCTOR RESERVES THE RIGHT TO MAKE CHANGES WITHOUT FURTHER NOTICE TO ANY PRODUCTS HEREIN TO IMPROVE RELIABILITY, FUNCTION, OR DESIGN. FAIRCHILD DOES NOT ASSUME ANY LIABILITY ARISING OUT OF THE APPLICATION OR USE OF ANY PRODUCT OR CIRCUIT DESCRIBED HEREIN; NEITHER DOES IT CONVEY ANY LICENSE UNDER ITS PATENT RIGHTS, NOR THE RIGHTS OF OTHERS. THESE SPECIFICATIONS DO NOT EXPAND THE TERMS OF FAIRCHILD'S WORLDWIDE TERMS AND CONDITIONS, SPECIFICALLY THE WARRANTY THEREIN, WHICH COVERS THESE PRODUCTS.

LIFE SUPPORT POLICY

FAIRCHILD'S PRODUCTS ARE NOT AUTHORIZED FOR USE AS CRITICAL COMPONENTS IN LIFE SUPPORT DEVICES OR SYSTEMS WITHOUT THE EXPRESS WRITTEN APPROVAL OF FAIRCHILD SEMICONDUCTOR CORPORATION.

As used herein:

- Life support devices or systems are devices or systems which, (a) are intended for surgical implant into the body, or (b) support or sustain life, or (c) whose failure to perform when properly used in accordance with instructions for use provided in the labeling, can be reasonably expected to result in significant injury to the user.
- A critical component is any component of a life support device or system whose failure to perform can be reasonably expected to cause the failure of the life support device or system, or to affect its safety or effectiveness.

PRODUCT STATUS DEFINITIONS

Definition of Terms

Datasheet Identification	Product Status	Definition
Advance Information	Formative or In Design	This datasheet contains the design specifications for product development. Specifications may change in any manner without notice.
Preliminary	First Production	This datasheet contains preliminary data, and supplementary data will be published at a later date. Fairchild Semiconductor reserves the right to make changes at any time without notice to improve design.
No Identification Needed	Full Production	This datasheet contains final specifications. Fairchild Semiconductor reserves the right to make changes at any time without notice to improve design.
Obsolete	Not In Production	This datasheet contains specifications on a product that has been discontinued by Fairchild semiconductor. The datasheet is printed for reference information only.

Rev. I20