

November 1996

1MHz, Four Quadrant Analog Multiplier

Features

- Accuracy $\pm 0.5\%$ ("A" Version)
- Input Voltage Range $\pm 10V$
- Bandwidth 1MHz
- Uses Standard $\pm 15V$ Supplies
- Built-in Op Amp Provides Level Shifting, Division and Square Root Functions

Description

The ICL8013 is a four quadrant analog multiplier whose output is proportional to the algebraic product of two input signals. Feedback around an internal op amp provides level shifting and can be used to generate division and square root functions. A simple arrangement of potentiometers may be used to trim gain accuracy, offset voltage and feedthrough performance. The high accuracy, wide bandwidth, and increased versatility of the ICL8013 make it ideal for all multiplier applications in control and instrumentation systems. Applications include RMS measuring equipment, frequency doublers, balanced modulators and demodulators, function generators, and voltage controlled amplifiers.

Ordering Information

PART NUMBER	MULTIPLICATION ERROR	TEMP. RANGE (°C)	PACKAGE	PKG. NO.
ICL8013AMTX	$\pm 0.5\%$	-55 to 125	10 Pin Metal Can	T10.B
ICL8013BMTX	$\pm 1\%$			
ICL8013ACTX	$\pm 0.5\%$	0 to 70	10 Pin Metal Can	T10.B
ICL8013BCTX	$\pm 1\%$			
ICL8013CCTX	$\pm 2\%$			

Pinout

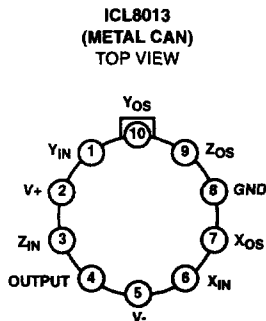

Functional Diagram

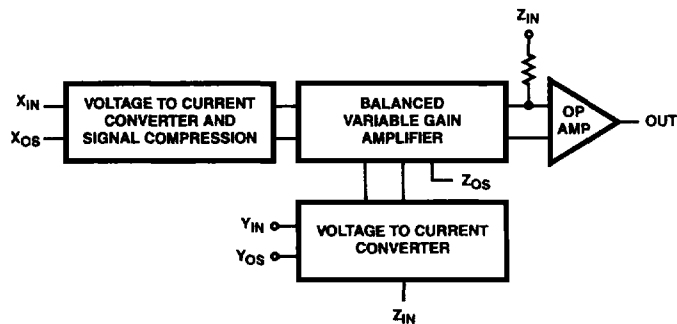

8
SPECIAL ANALOG
CIRCUITS

ICL8013

Absolute Maximum Ratings

Supply Voltage ± 18
 Input Voltages (X_{IN} , Y_{IN} , Z_{IN} , X_{OS} , Y_{OS} , Z_{OS}) V_{SUPPLY}

Operating Conditions

Temperature Range
 ICL8013XC 0°C to 70°C
 ICL8013XM -55°C to 125°C

Thermal Information

Thermal Resistance (Typical, Note 1) θ_{JA} ($^{\circ}\text{C}/\text{W}$) θ_{JC} ($^{\circ}\text{C}/\text{W}$)
 Metal Can Package 160 75
 Maximum Junction Temperature (Metal Can Package) 175°C
 Maximum Storage Temperature Range -65°C to 150°C
 Maximum Lead Temperature (Soldering 10s) 300°C

CAUTION: Stresses above those listed in "Absolute Maximum Ratings" may cause permanent damage to the device. This is a stress only rating and operation of the device at these or any other conditions above those indicated in the operational sections of this specification is not implied.

NOTE:

- θ_{JA} is measured with the component mounted on an evaluation PC board in free air.

Electrical Specifications

$T_A = 25^{\circ}\text{C}$, $V_{SUPPLY} = \pm 15\text{V}$, Gain and Offset Potentiometers Externally Trimmed, Unless Otherwise Specified

PARAMETER	TEST CONDITIONS	ICL8013A			ICL8013B			ICL8013C			UNITS
		MIN	TYP	MAX	MIN	TYP	MAX	MIN	TYP	MAX	
Multiplier Function		-	$\frac{XY}{10}$	-	-	$\frac{XY}{10}$	-	-	$\frac{XY}{10}$	-	
Multiplication Error	$-10 < X < 10$ $-10 < Y < 10$	-	-	0.5	-	-	1.0	-	-	2.0	% Full Scale
Divider Function		-	$\frac{10Z}{X}$	-	-	$\frac{10Z}{X}$	-	-	$\frac{10Z}{X}$	-	
Division Error	$X = -10$	-	0.3	-	-	0.3	-	-	0.3	-	% Full Scale
	$X = -1$	-	1.5	-	-	1.5	-	-	1.5	-	% Full Scale
Feedthrough	$X = 0, Y = \pm 10\text{V}$	-	-	50	-	-	100	-	-	200	mV
	$Y = 0, X = \pm 10\text{V}$	-	-	50	-	-	100	-	-	150	mV
Non-Linearity	X Input $X = 20\text{V}_{\text{P-P}}$ $Y = \pm 10\text{V}_{\text{DC}}$	-	± 0.5	-	-	± 0.5	-	-	± 0.8	-	%
	Y Input $Y = 20\text{V}_{\text{P-P}}$ $X = \pm 10\text{V}_{\text{DC}}$	-	± 0.2	-	-	± 0.2	-	-	± 0.3	-	%
Frequency Response Small Signal Bandwidth (-3dB)		-	1.0	-	-	1.0	-	-	1.0	-	MHz
Full Power Bandwidth		-	750	-	-	750	-	-	750	-	kHz
Slew Rate		-	45	-	-	45	-	-	45	-	V/ μs
1% Amplitude Error		-	75	-	-	75	-	-	75	-	kHz
1% Vector Error (0.5° Phase Shift)		-	5	-	-	5	-	-	5	-	kHz
Settling Time (to $\pm 2\%$ of Final Value)	$V_{IN} = \pm 10\text{V}$	-	1	-	-	1	-	-	1	-	μs
Overload Recovery (to $\pm 2\%$ of Final Value)	$V_{IN} = \pm 10\text{V}$	-	1	-	-	1	-	-	1	-	μs
Output Noise	5Hz to 10kHz	-	0.6	-	-	0.6	-	-	0.6	-	mV _{RMS}
	5Hz to 5MHz	-	3	-	-	3	-	-	3	-	mV _{RMS}
Input Resistance	$V_{IN} = 0\text{V}$	X Input	-	10	-	-	10	-	-	10	$\text{M}\Omega$
		Y Input	-	6	-	-	6	-	-	6	$\text{M}\Omega$
		Z Input	-	36	-	-	36	-	-	36	k Ω
Input Bias Current	$V_{IN} = 0\text{V}$	X or Y Input	-	2	5	-	7.5	-	-	10	μA
		Z Input	-	25	-	-	25	-	-	25	μA

ICL8013

Electrical Specifications $T_A = 25^\circ\text{C}$, $V_{\text{SUPPLY}} = \pm 15\text{V}$, Gain and Offset Potentiometers Externally Trimmed, Unless Otherwise Specified (Continued)

PARAMETER	TEST CONDITIONS	ICL8013A			ICL8013B			ICL8013C			UNITS
		MIN	TYP	MAX	MIN	TYP	MAX	MIN	TYP	MAX	
Power Supply Variation		-		-	-		-	-		-	
Multiplication Error		-	0.2		-	0.2		-	0.2		%/%
Output Offset		-	-	50	-	-	75	-	-	100	mV/V
Scale Factor		-	0.1	-	-	0.1	-	-	0.1	-	%/%
Quiescent Current		-	3.5	6.0	-	3.5	6.0	-	3.5	6.0	mA
THE FOLLOWING SPECIFICATIONS APPLY OVER THE OPERATING TEMPERATURE RANGES											
Multiplication Error	$-10\text{V} < X_{\text{IN}} < 10\text{V}$, $-10\text{V} < Y_{\text{IN}} < 10\text{V}$	-	1.5	-	-	2	-	-	3	-	% Full Scale
Average Temp. Coefficients		-		-	-		-	-		-	
Accuracy		-	0.06	-	-	0.06	-	-	0.06	-	%/°C
Output Offset		-	0.2	-	-	0.2	-	-	0.2	-	mV/°C
Scale Factor		-	0.04	-	-	0.04	-	-	0.04	-	%/°C
Input Bias Current		-	-	-	-	-	-	-	-	-	
X or Y Input	$V_{\text{IN}} = 0\text{V}$	-	-	5	-	-	5	-	-	10	μA
Z Input		-	-	25	-	-	25	-	-	35	μA
Input Voltage (X, Y, or Z)		-	-	± 10	-	-	± 10	-	-	± 10	V
Output Voltage Swing	$R_L \geq 2\text{k}\Omega$ $C_L < 1000\text{pF}$	-	± 10	-	-	± 10	-	-	± 10	-	V

Schematic Diagram

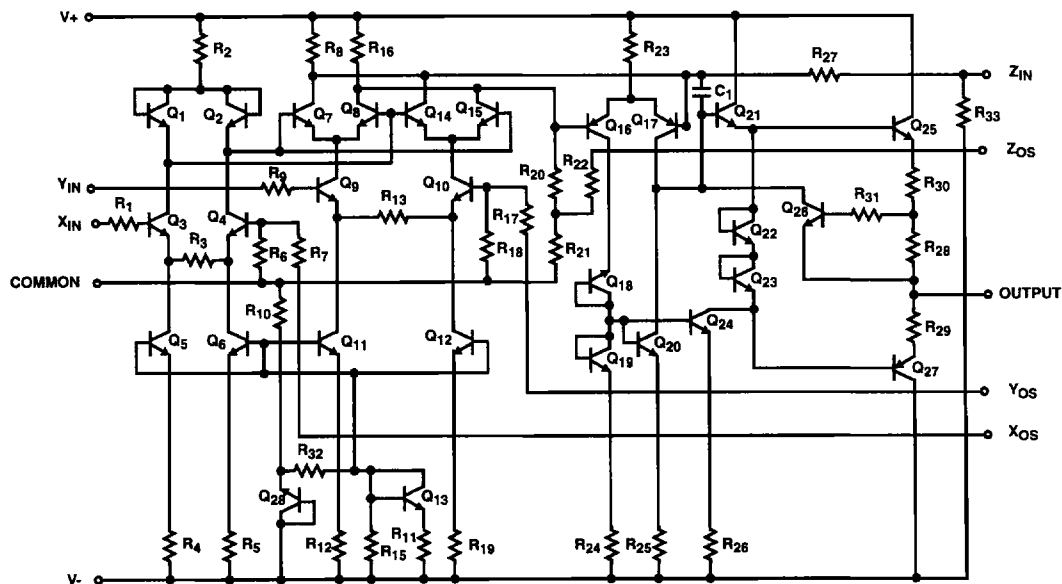

Application Information

Detailed Circuit Description

The fundamental element of the ICL8013 multiplier is the bipolar differential amplifier of Figure 1.

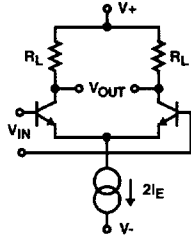

FIGURE 1. DIFFERENTIAL AMPLIFIER

The small signal differential voltage gain of this circuit is given by:

$$A_V = \frac{V_{OUT}}{V_{IN}} = \frac{R_L}{r_E}$$

$$\text{Substituting } r_E = \frac{1}{g_M} = \frac{kT}{qI_E}$$

$$V_{OUT} = V_{IN} \left(\frac{R_L}{r_E} \right) = V_{IN} \times \frac{qI_E R_L}{kT}$$

The output voltage is thus proportional to the product of the input voltage V_{IN} and the emitter current I_E . In the simple transconductance multiplier of Figure 2, a current source comprising Q_3 , D_1 , and R_Y is used. If V_Y is large compared with the drop across D_1 , then

$$I_D = \frac{V_Y}{R_Y} = 2I_E \text{ and}$$

$$V_{OUT} = \frac{qR_L}{kTR_Y} (V_X \times V_Y)$$

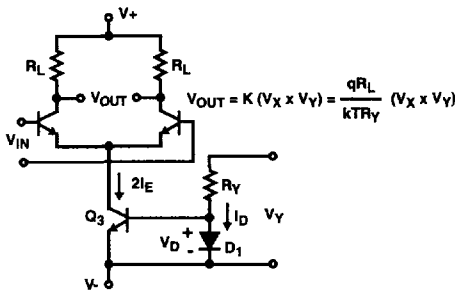

FIGURE 2. TRANSCONDUCTANCE MULTIPLIER

There are several difficulties with this simple modulator:

1. V_Y must be positive and greater than V_D .
2. Some portion of the signal at V_X will appear at the output unless $I_E = 0$.
3. V_X must be a small signal for the differential pair to be linear.
4. The output voltage is not centered around ground.

The first problem relates to the method of converting the V_Y voltage to a current to vary the gain of the V_X differential pair. A better method, Figure 3, uses another differential pair but with considerable emitter degeneration. In this circuit the differential input voltage appears across the common emitter resistor, producing a current which adds or subtracts from the quiescent current in either collector. This type of voltage to current converter handles signals from 0V to $\pm 10V$ with excellent linearity.

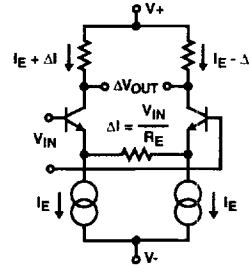

FIGURE 3. VOLTAGE TO CURRENT CONVERTER

The second problem is called feedthrough: i.e., the product of zero and some finite input signal does not produce zero output voltage. The circuit whose operation is illustrated by Figures 4A, 4B, and 4C overcomes this problem and forms the heart of many multiplier circuits in use today.

This circuit is basically two matched differential pairs with cross coupled collectors. Consider the case shown in Figure 4A of exactly equal current sources biasing the two pairs. With a small positive signal at V_{IN} , the collector current of Q_1 and Q_4 will increase but the collector currents of Q_2 and Q_3 will decrease by the same amount. Since the collectors are cross coupled the current through the load resistors remains unchanged and independent of the V_{IN} input voltage.

In Figure 4B, notice that with $V_{IN} = 0$ any variation in the ratio of biasing current sources will produce a common mode voltage across the load resistors. The differential output voltage will remain zero. In Figure 4C we apply a differential input voltage with unbalanced current sources. If I_{E1} is twice I_{E2} the gain of differential pair Q_1 and Q_2 is twice the gain of pair Q_3 and Q_4 . Therefore, the change in cross coupled collector currents will be unequal and a differential output voltage will result. By replacing the separate biasing current sources with the voltage to current converter of Figure 3 we have a balanced multiplier circuit capable of four quadrant operation (Figure 5).

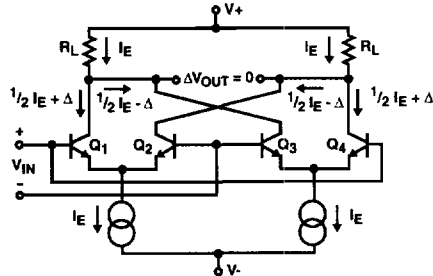

FIGURE 4A. INPUT SIGNAL WITH BALANCED CURRENT SOURCES $\Delta V_{OUT} = 0V$

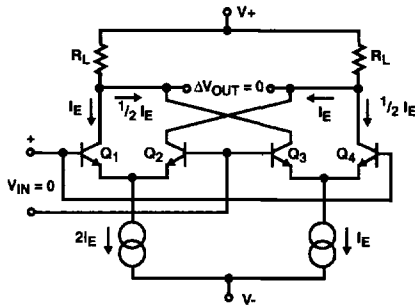

FIGURE 4B. NO INPUT SIGNAL WITH UNBALANCED CURRENT SOURCES $\Delta V_{OUT} = 0V$

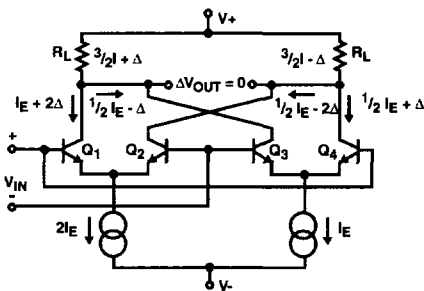

FIGURE 4C. INPUT SIGNAL WITH UNBALANCED CURRENT SOURCES, DIFFERENTIAL OUTPUT VOLTAGE

This circuit of Figure 5 still has the problem that the input voltage V_{IN} must be small to keep the differential amplifier in the linear region. To be able to handle large signals, we need an amplitude compression circuit.

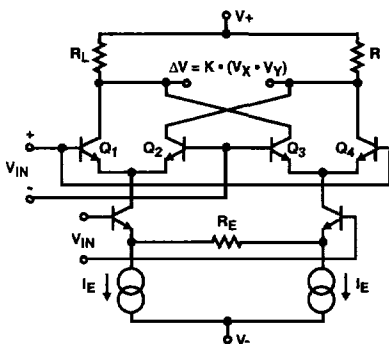

FIGURE 5. TYPICAL FOUR QUADRANT MULTIPLIER-MODULATOR

Figure 2 showed a current source formed by relying on the matching characteristics of a diode and the emitter base junction of a transistor. Extension of this idea to a differential circuit is shown in Figure 6A. In a differential pair, the input voltage splits the biasing current in a logarithmic ratio. (The usual

assumption of linearity is useful only for small signals.) Since the input to the differential pair in Figure 6A is the difference in voltage across the two diodes, which in turn is proportional to the log of the ratio of drive currents, it follows that the ratio of diode currents and the ratio of collector currents are linearly related and independent of amplitude. If we combine this circuit with the voltage to current converter of Figure 3, we have Figure 6B. The output of the differential amplifier is now proportional to the input voltage over a large dynamic range, thereby improving linearity while minimizing drift and noise factors.

The complete schematic is shown after the Electrical Specifications Table. The differential pair Q_3 and Q_4 form a voltage to current converter whose output is compressed in collector diodes Q_1 and Q_2 . These diodes drive the balanced cross-coupled differential amplifier Q_7/Q_8 Q_{14}/Q_{15} . The gain of these amplifiers is modulated by the voltage to current converter Q_9 and Q_{10} . Transistors Q_5 , Q_6 , Q_{11} , and Q_{12} are constant current sources which bias the voltage to current converter. The output amplifier comprises transistors Q_{16} through Q_{27} .

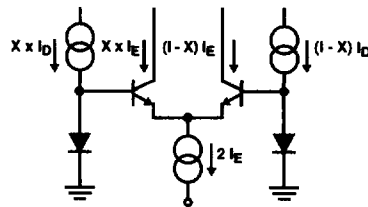

FIGURE 6A. CURRENT GAIN CELL

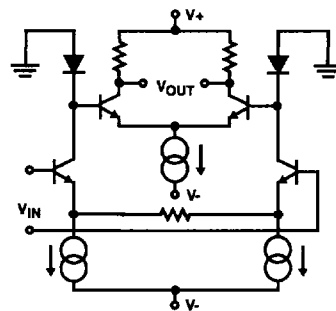

FIGURE 6B. VOLTAGE GAIN WITH SIGNAL COMPRESSION

Definition of Terms

Multiplication/Division Error: This is the basic accuracy specification. It includes terms due to linearity, gain, and offset errors, and is expressed as a percentage of the full scale output.

Feedthrough: With either input at zero, the output of an ideal multiplier should be zero regardless of the signal applied to the other input. The output seen in a non-ideal multiplier is known as the feedthrough.

Nonlinearity: The maximum deviation from the best straight line constructed through the output data, expressed as a percentage of full scale. One input is held constant and

the other swept through its nominal range. The nonlinearity is the component of the total multiplication/division error which cannot be trimmed out.

Typical Applications

Multiplication

In the standard multiplier connection, the Z terminal is connected to the op amp output. All of the modulator output current thus flows through the feedback resistor R_{27} and produces a proportional output voltage.

Multiplier Trimming Procedure

1. Set $X_{IN} = Y_{IN} = 0V$ and adjust Z_{OS} for zero Output.
2. Apply a $\pm 10V$ low frequency ($\leq 100Hz$) sweep (sine or triangle) to Y_{IN} with $X_{IN} = 0V$, and adjust X_{OS} for minimum output.
3. Apply the sweep signal of Step 2 to X_{IN} with $Y_{IN} = 0V$ and adjust Y_{OS} for minimum Output.
4. Readjust Z_{OS} as in Step 1, if necessary.
5. With $X_{IN} = 10.0V_{DC}$ and the sweep signal of Step 2 applied to Y_{IN} , adjust the Gain potentiometer for Output = Y_{IN} . This is easily accomplished with a differential scope plug-in (A+B) by inverting one signal and adjusting Gain control for (Output - Y_{IN}) = Zero.

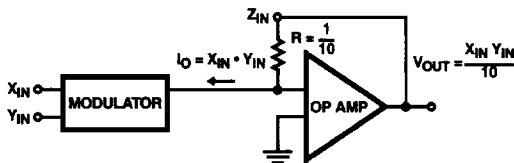

FIGURE 7A. MULTIPLIER BLOCK DIAGRAM

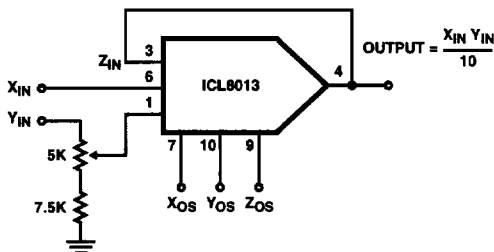

FIGURE 7B. MULTIPLIER CIRCUIT CONNECTION

Division

If the Z terminal is used as an input, and the output of the op amp connected to the Y input, the device functions as a divider. Since the input to the op amp is at virtual ground, and requires negligible bias current, the overall feedback forces the modulator output current to equal the current produced by Z.

$$\text{Therefore } I_O = X_{IN} \cdot Y_{IN} = \frac{Z_{IN}}{R} = 10Z_{IN}$$

$$\text{Since } Y_{IN} = V_{OUT} \cdot V_{OUT} = \frac{10Z_{IN}}{X_{IN}}$$

Note that when connected as a divider, the X input must be a negative voltage to maintain overall negative feedback.

Divider Trimming Procedure

1. Set trimming potentiometers at mid-scale by adjusting voltage on pins 7, 9 and 10 (X_{OS} , Y_{OS} , Z_{OS}) for 0V.
2. With $Z_{IN} = 0V$, trim Z_{OS} to hold the Output constant, as X_{IN} is varied from -10V through -1V.
3. With $Z_{IN} = 0V$ and $X_{IN} = -10.0V$ adjust Y_{OS} for zero Output voltage.
4. With $Z_{IN} = X_{IN}$ (and/or $Z_{IN} = -X_{IN}$) adjust X_{OS} for minimum worst case variation of Output, as X_{IN} is varied from -10V to -1V.
5. Repeat Steps 2 and 3 if Step 4 required a large initial adjustment.
6. With $Z_{IN} = X_{IN}$ (and/or $Z_{IN} = -X_{IN}$) adjust the gain control until the output is the closest average around +10.0V (-10V for $Z_{IN} = -X_{IN}$) as X_{IN} is varied from -10V to -3V.

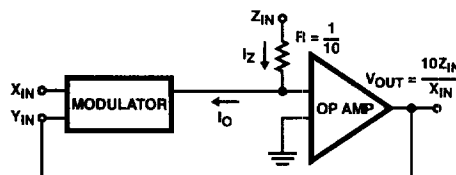

FIGURE 8A. DIVISION BLOCK DIAGRAM

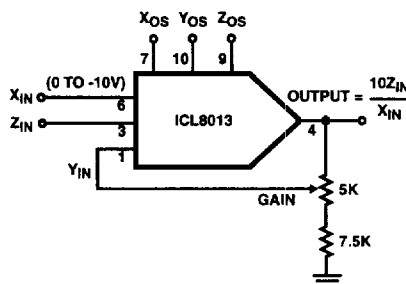

FIGURE 8B. DIVISION CIRCUIT CONNECTION

Squaring

The squaring function is achieved by simply multiplying with the two inputs tied together. The squaring circuit may also be used as the basis for a frequency doubler since $\cos^2 \omega t = \frac{1}{2}(\cos 2\omega t + 1)$.

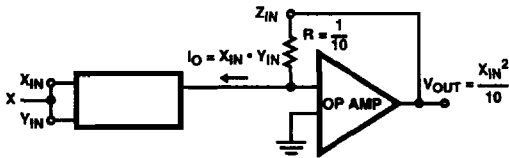

FIGURE 9A. SQUARER BLOCK DIAGRAM

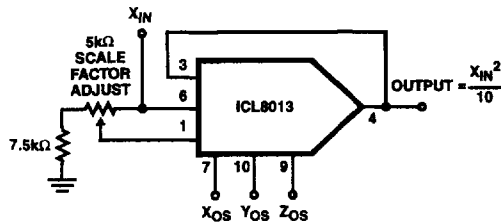

FIGURE 9B. SQUARER CIRCUIT CONNECTION

Square Root

Tying the X and Y inputs together and using overall feedback from the op amp results in the square root function. The output of the modulator is again forced to equal the current produced by the Z input.

$$I_O = X_{IN} \times Y_{IN} = (-V_{OUT})^2 = 10Z_{IN}$$

$$V_{OUT} = -\sqrt{10Z_{IN}}$$

The output is a negative voltage which maintains overall negative feedback. A diode in series with the op amp output prevents the latchup that would otherwise occur for negative input voltages.

Square Root Trimming Procedure

1. Connect the ICL8013 in the Divider configuration.
2. Adjust Z_{OS}, Y_{OS}, X_{OS}, and Gain using Steps 1 through 6 of Divider Trimming Procedure.
3. Convert to the Square Root configuration by connecting X_{IN} to the output and inserting a diode between Pin 4 and the output node.
4. With Z_{IN} = 0V adjust Z_{OS} for zero output voltage.

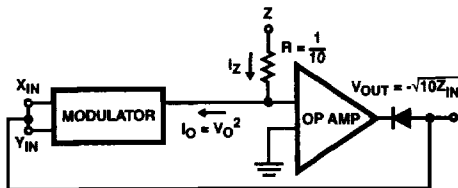

FIGURE 10A. SQUARE ROOT BLOCK DIAGRAM

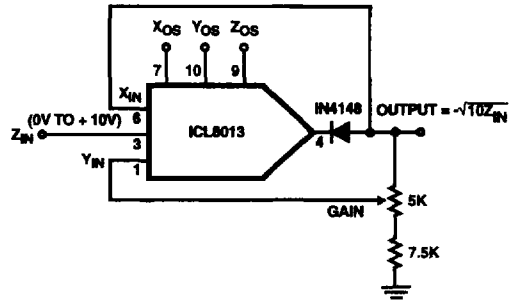

FIGURE 10B. ACTUAL CIRCUIT CONNECTION

Variable Gain Amplifier

Most applications for the ICL8013 are straight forward variations of the simple arithmetic functions described above. Although the circuit description frequently disguises the fact, it has already been shown that the frequency doubler is nothing more than a squaring circuit. Similarly the variable gain amplifier is nothing more than a multiplier, with the input signal applied at the X input and the control voltage applied at the Y input.

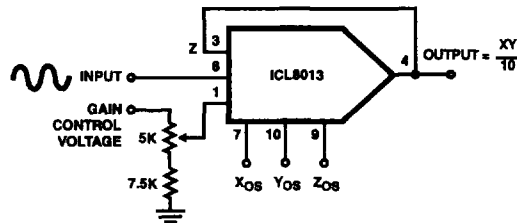

FIGURE 11. VARIABLE GAIN AMPLIFIER

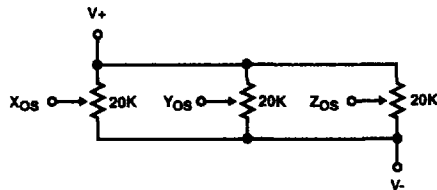

FIGURE 12. POTENTIOMETERS FOR TRIMMING OFFSET AND FEEDTHROUGH

Typical Performance Curves

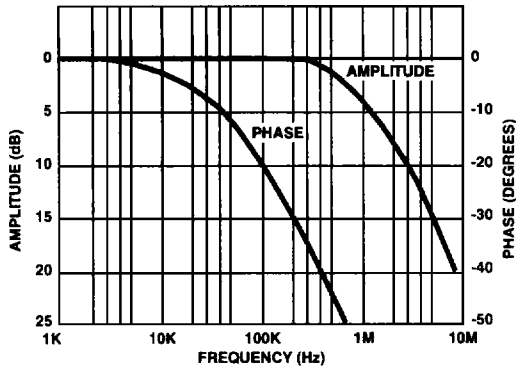

FIGURE 13. FREQUENCY RESPONSE

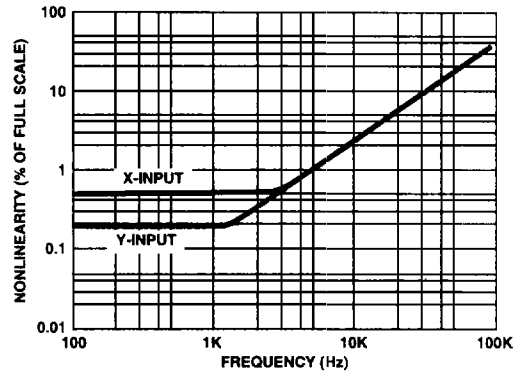

FIGURE 14. NONLINEARITY vs FREQUENCY

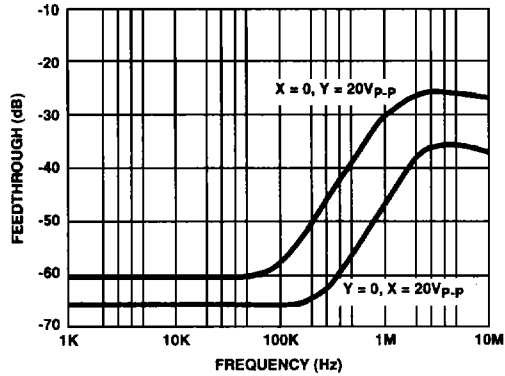

FIGURE 15. FEEDTHROUGH vs FREQUENCY