

Single Channel 16-bit CIS/CCD AFE with RGB LED Current Drive

DESCRIPTION

The WM8255 is a 16-bit analogue front end/digitiser IC which processes and digitises the analogue output signals from CCD sensors or Contact Image Sensors (CIS) at pixel sample rates of up to 12 MSPS.

The device includes a complete signal processing channel containing Reset Level Clamping, Correlated Double Sampling, Programmable Gain and Offset adjust functions. Internal multiplexers allow fast switching of offset and gain for line-by-line colour processing. The output from this channel is time multiplexed into a high-speed 16-bit Analogue to Digital Converter. The digital output data is available in a 2 bit or 4-bit wide multiplexed format.

An internal 4-bit DAC is supplied for internal reference level generation. This may be used during CDS to reference CIS signals or during Reset Level Clamping to clamp CCD signals. An external reference level may also be supplied. ADC references are generated internally, ensuring optimum performance from the device.

The device includes an RGB LED current drive using current and PWM functionality to control the operation of sensor LEDs.

The device typically uses an analogue supply voltage of 5.75V and a digital interface supply of 3.3V.

FEATURES

- 16-bit ADC
- 12 MSPS conversion rate
- Low power – 250 mW typical
- 5.75V and 3.3V supply operation
- Single channel operation
- Correlated double sampling
- Programmable gain (8-bit resolution)
- Programmable offset adjust (8-bit resolution)
- Programmable clamp voltage
- RGB LED current drive using current and PWM
- 2-bit or 4-bit wide multiplexed data output format
- Internally generated voltage references
- 28-lead QFN package
- 3 wire serial control interface

APPLICATIONS

- Flatbed and sheetfeed scanners
- USB compatible scanners
- Multi-function peripherals

BLOCK DIAGRAM

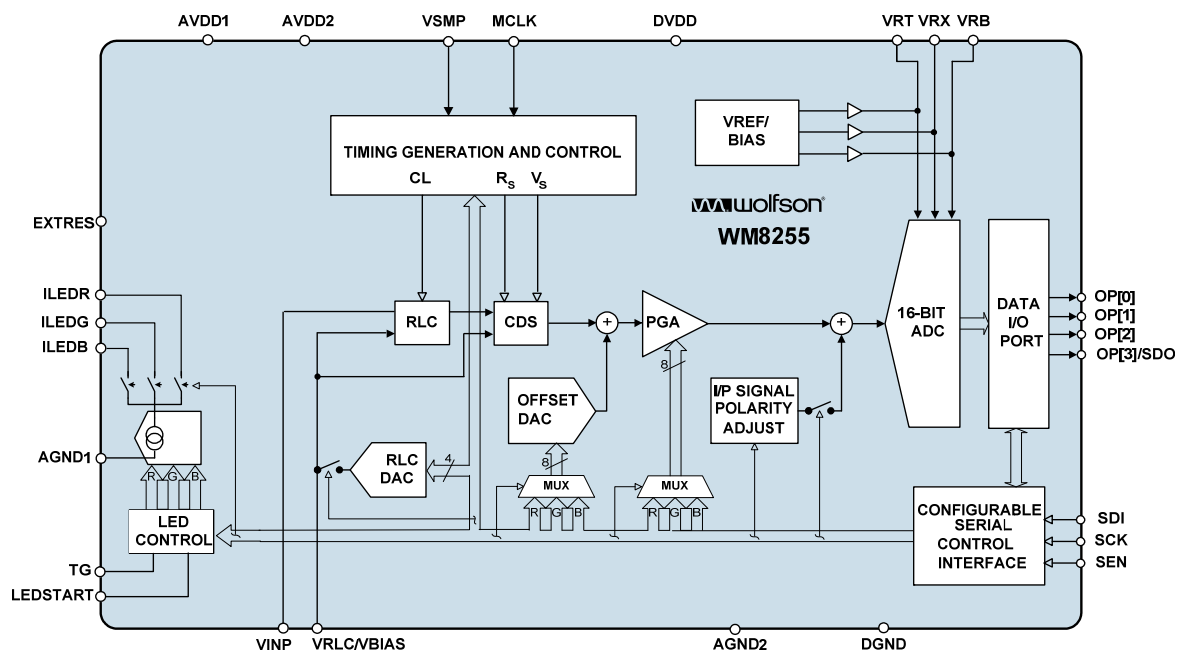
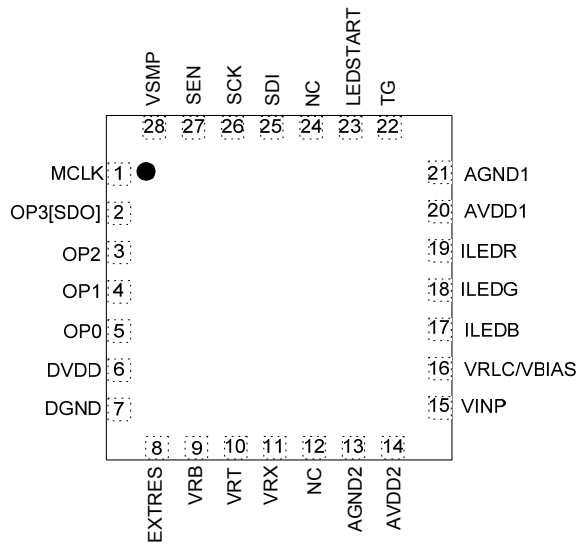

TABLE OF CONTENTS

DESCRIPTION	1
FEATURES	1
APPLICATIONS	1
BLOCK DIAGRAM	1
TABLE OF CONTENTS	2
PIN CONFIGURATION	4
ORDERING INFORMATION	4
PIN DESCRIPTION	5
ABSOLUTE MAXIMUM RATINGS	6
RECOMMENDED OPERATING CONDITIONS	6
THERMAL PERFORMANCE	6
ELECTRICAL CHARACTERISTICS	7
INPUT VIDEO SAMPLING	10
OUTPUT DATA TIMING.....	10
SERIAL INTERFACE	11
PWM TIMING	12
DEVICE DESCRIPTION	13
INTRODUCTION.....	13
INPUT SAMPLING	13
RESET LEVEL CLAMPING (RLC).....	13
CDS/NON-CDS PROCESSING	14
OFFSET ADJUST AND PROGRAMMABLE GAIN	15
ADC INPUT BLACK LEVEL ADJUST	16
OVERALL SIGNAL FLOW SUMMARY	16
CALCULATING OUTPUT FOR ANY GIVEN INPUT.....	16
OUTPUT FORMATS	18
LED CURRENT DRIVE CONTROL	19
LED CURRENT DRIVE SEQUENCE SYNCHRONISATION AND PROGRESSION.....	20
LED CURRENT DRIVE INTENSITY CONTROL.....	21
LED CURRENT DRIVE CURRENT PWM CONTROL	25
LED CURRENT DRIVE CURRENT BLANKING PERIOD	26
CURRENT ACCURACY AND ABSOLUTE MAXIMUM CURRENT LIMIT	30
LED CONTROL WORKED EXAMPLE.....	32
CONTROL INTERFACE.....	34
TIMING REQUIREMENTS	34
PROGRAMMABLE VSMP DETECT CIRCUIT.....	35
REFERENCES.....	36
POWER SUPPLY.....	36
POWER MANAGEMENT	36
POWER ON SEQUENCE	37
OPERATING MODES	37
OPERATING MODE TIMING DIAGRAMS.....	38
DEVICE REVISION CODES	39
DEVICE CONFIGURATION	40
REGISTER MAP	40
EXTENDED PAGE REGISTERS	41
REGISTER MAP DESCRIPTION.....	41
EXTENDED PAGE REGISTER MAP DESCRIPTION	45
RECOMMENDED EXTERNAL COMPONENTS	46

PACKAGE DIMENSIONS	47
QFN 5 X 5 X 0.85MM	47
QFN 4 X 4 X 0.85MM	47
IMPORTANT NOTICE	48
ADDRESS:	48
REVISION HISTORY	49

PIN CONFIGURATION



ORDERING INFORMATION

DEVICE	TEMPERATURE RANGE	PACKAGE	MOISTURE SENSITIVITY LEVEL	PEAK SOLDERING TEMPERATURE
WM8255BGEFL/V	0 to 85°C	4x4x0.85mm 28-lead QFN (Pb-free)	MSL3	260°C
WM8255BGEFL/RV	0 to 85°C	4x4x0.85mm 28-lead QFN (Pb-free, tape and reel)	MSL3	260°C

Note:

Reel quantity = 3,500

PIN DESCRIPTION

PIN NO	NAME	TYPE	DESCRIPTION																				
1	MCLK	Digital input	Master clock. This clock is applied at N times the input pixel rate (N = 2, 3, 4, 6, 8 or any multiple of 2 thereafter depending on input sample mode).																				
			Digital multiplexed output data bus. ADC output data (d15:d0) is available in a 4-bit multiplexed format as shown below. A 2-bit multiplexed output is also available as described in the OUTPUT FORMATS section of this datasheet on page 18.																				
			<table border="1" style="width: 100%; border-collapse: collapse;"> <thead> <tr> <th style="width: 25%;">A</th> <th style="width: 25%;">B</th> <th style="width: 25%;">C</th> <th style="width: 25%;">D</th> </tr> </thead> <tbody> <tr> <td>d15</td> <td>d11</td> <td>d7</td> <td>d3</td> </tr> <tr> <td>d14</td> <td>d10</td> <td>d6</td> <td>d2</td> </tr> <tr> <td>d13</td> <td>d9</td> <td>d5</td> <td>d1</td> </tr> <tr> <td>d12</td> <td>d8</td> <td>d4</td> <td>d0</td> </tr> </tbody> </table>	A	B	C	D	d15	d11	d7	d3	d14	d10	d6	d2	d13	d9	d5	d1	d12	d8	d4	d0
A	B	C	D																				
d15	d11	d7	d3																				
d14	d10	d6	d2																				
d13	d9	d5	d1																				
d12	d8	d4	d0																				
2	OP[3]/SDO	Digital output																					
3	OP[2]	Digital output																					
4	OP[1]	Digital output																					
5	OP[0]	Digital output																					
			Alternatively, pin OP[3]/SDO may be used to output register read-back data when address bit 4=1 and SEN has been pulsed high. See Serial Interface description in Device Description section for further details.																				
6	DVDD	Supply	Digital supply (3.3V)																				
7	DGND	Supply	Digital ground (0V).																				
8	EXTRES	Analogue input	External resistor connection for LED absolute current control. Must be connected to ground via a suitable resistor.																				
9	VRB	Analogue output	Lower reference voltage. This pin must be connected to AGND via a decoupling capacitor.																				
10	VRT	Analogue output	Upper reference voltage. This pin must be connected to AGND via a decoupling capacitor.																				
11	VRX	Analogue output	Input return bias voltage This pin must be connected to AGND via a decoupling capacitor.																				
12	NC	No Connect	Not Connected.																				
13	AGND2	Supply	Analogue ground pin (0V)																				
14	AVDD2	Supply	Analogue supply (3.3V) Not required to be driven if AVDD1 is being used. A decoupling capacitor must be connected to AGND.																				
15	VINP	Analogue input	Video input.																				
16	VRLC/VBIAS	Analogue I/O	Selectable analogue output voltage for RLC or single-ended bias reference. This pin would typically be connected to AGND via a decoupling capacitor. VRLC can be externally driven if programmed Hi-Z.																				
17	ILED B	Analogue input	Blue LED pin																				
18	ILED G	Analogue input	Green LED pin																				
19	ILED R	Analogue input	Red LED pin																				
20	AVDD1	Supply	Analogue Supply (5.75V)																				
21	AGND1	Supply	Analogue ground (0V).																				
22	TG	Digital input	Line synchronisation pulse																				
23	LEDSTART	Digital input	LED start pulse																				
24	NC	No Connect	Not Connected.																				
25	SDI	Digital input	Serial data input.																				
26	SCK	Digital input	Serial clock																				
27	SEN	Digital input	Enables the serial interface when high.																				
28	VSMP	Digital input	Video sample synchronisation pulse.																				

ABSOLUTE MAXIMUM RATINGS

Absolute Maximum Ratings are stress ratings only. Permanent damage to the device may be caused by continuously operating at or beyond these limits. Device functional operating limits and guaranteed performance specifications are given under Electrical Characteristics at the test conditions specified.



ESD Sensitive Device. This device is manufactured on a CMOS process. It is therefore generically susceptible to damage from excessive static voltages. Proper ESD precautions must be taken during handling and storage of this device.

The WM8255 has been classified as MSL1, which has an unlimited floor life at 30°C / 85% Relative Humidity and therefore will not be supplied in moisture barrier bags.

CONDITION	MIN	MAX
Analogue supply voltage: AVDD1	GND - 0.3V	GND + 7V
Analogue supply voltage: AVDD2	GND - 0.3V	GND + 4.2V
Digital core supply and I/O voltage: DVDD	GND - 0.3V	GND + 4.2V
Digital ground: DGND	GND - 0.3V	GND + 0.3V
Analogue grounds AGND	GND - 0.3V	GND + 0.3V
Digital inputs, digital outputs and digital I/O pins	GND - 0.3V	DVDD + 0.3V
Analogue input VINP	GND - 0.3V	AVDD + 0.3V
Other pins	GND - 0.3V	AVDD + 0.3V
Operating temperature range: T_A	0°C	$+85^{\circ}\text{C}$

Notes:

- GND denotes the voltage of any ground pin.
- AGND and DGND pins are intended to be operated at the same potential. Differential voltages between these pins will degrade performance.

RECOMMENDED OPERATING CONDITIONS

CONDITION	SYMBOL	MIN	TYP	MAX	UNITS
Operating temperature range	T_A	0		85	$^{\circ}\text{C}$
Analogue supply voltage	AVDD1	4.75	5.75	6.0	V
Analogue supply voltage ¹	AVDD2	2.97	3.3	3.63	V
Digital Core and I/O supply voltage	DVDD	2.97	3.3	3.63	V

Notes

- AVDD2 supply not required if using AVDD1. AVDD2 would require connection to ground via a capacitor in that situation.
- If AVDD2 is being used, both AVDD2 and DVDD should be operated at the same potential.

THERMAL PERFORMANCE

PARAMETER	SYMBOL	TEST CONDITIONS	MIN	TYP	MAX	UNIT
Performance						
Thermal resistance – junction to case (5x5x0.9mm package)	$R_{\theta\text{JC}}$	$T_{\text{ambient}} = 25^{\circ}\text{C}$		10.27		$^{\circ}\text{C}/\text{W}$
Thermal resistance – junction to ambient (5x5x0.9mm package)	$R_{\theta\text{JA}}$			29.45		$^{\circ}\text{C}/\text{W}$
Thermal resistance – junction to ambient (4x4x0.85mm package)	$R_{\theta\text{JA}}$			24.05		$^{\circ}\text{C}/\text{W}$

Notes:

- Figures given are for package mounted on 4-layer FR4 according to JESD51-5 and JESD51-7.

ELECTRICAL CHARACTERISTICS

Test Conditions

AVDD1 = 5.75V, DVDD = 3.3V, AGND = DGND = AVDD2 = 0V, T_A = 25°C, MCLK = 24MHz, mode 1 unless otherwise stated.

PARAMETER	SYMBOL	TEST CONDITIONS	MIN	TYP	MAX	UNIT
Overall System Specification (including 16-bit ADC, PGA, Offset and CDS functions)						
Full-scale input voltage range (see Note 1)		Max Gain Min Gain		0.24 2.56		V _{p-p} V _{p-p}
Input signal limits (see Note 2)	V _{IN}		0		AVDD1	V
Full-scale transition error		Gain = 0dB; PGA[7:0] = 07(hex)	-50	10	+50	mV
Zero-scale transition error		Gain = 0dB; PGA[7:0] = 07(hex)	-50	10	+50	mV
Differential non-linearity	DNL			1.5		LSB
Integral non-linearity	INL			25		LSB
Input referred noise				9		LSB rms
References						
Upper reference voltage	VRT			2.05		V
Lower reference voltage	VRB			1.05		V
Diff. reference voltage (VRT-VRB)	V _{RTB}			1.0		V
Output resistance VRT, VRB, VRX				1		Ω
VRLC/Reset-Level Clamp (RLC)						
RLC switching impedance			10	50	100	Ω
VRLC short-circuit current				8		mA
VRLC output resistance				2		Ω
VRLC Hi-Z leakage current		VRLC = 0 to AVDD1			1	μA
RLCDAC resolution				4		bits
RLCDAC step size	V _{RLCSTEP}			0.24		V/step
RLCDAC output voltage at code 0(hex)	V _{RLCBOT}			0.3		V
RLCDAC output voltage at code F(hex)	V _{RLCTOP}			3.9		V
Offset DAC, Monotonicity Guaranteed						
Resolution				8		bits
Differential non-linearity	DNL			0.6		LSB
Integral non-linearity	INL			2		LSB
Step size				1.96		mV/step
Output voltage		Code 00(hex) Code FF(hex)	-220 +220	-250 +250	-280 +280	mV mV

Notes:

1. **Full-scale input voltage** denotes the peak input signal amplitude that can be gained to match the ADC input range.
2. **Input signal limits** are the limits within which the full-scale input voltage signal must lie.

Test ConditionsAVDD1 = 5.75V, DVDD = 3.3V, AGND = DGND = AVDD2 = 0V, T_A = 25°C, MCLK = 24MHz unless otherwise stated.

PARAMETER	SYMBOL	TEST CONDITIONS	MIN	TYP	MAX	UNIT
Programmable Gain Amplifier						
Resolution				8		bits
Gain equation				$0.78 + \frac{\text{PGA}[7:0] \times 7.57}{255}$		V/V
Max gain	G _{MAX}		8	8.35	8.7	V/V
Min gain	G _{MIN}		0.72	0.78	0.82	V/V
Internal channel offset	V _{OFF}			10		mV
Analogue to Digital Converter						
Resolution				16		bits
Maximum Speed					12	MSPS
Full-scale input range (2*(VRT-VRB))	V _{FS}			2.0		V
DIGITAL SPECIFICATIONS						
Digital Inputs						
High level input voltage	V _{IH}		0.7 * DVDD			V
Low level input voltage	V _{IL}				0.2 * DVDD	V
High level input current	I _{IH}				1	μA
Low level input current	I _{IL}				1	μA
Input capacitance	C _I			5		pF
Digital Outputs						
High level output voltage	V _{OH}	I _{OH} = 1mA	DVDD - 0.5			V
Low level output voltage	V _{OL}	I _{OL} = 1mA			0.5	V
Supply Currents (LED Current DAC switched off)						
Total supply current – active				42.5		mA
Total analogue AVDD, supply current – active	I _{AVDD}			39		mA
Total digital core, DVDD, supply current – active	I _{DVDD1}			3.5		mA
Supply current – full power down mode				500		μA

Notes:

- Digital I/O supply current depends on the capacitive load attached to the pin. The Digital I/O supply current is measured with approximately 50pF attached to the pin.

PARAMETER	SYMBOL	TEST CONDITIONS	MIN	TYP	MAX	UNIT
EXTERNAL LED CURRENT DRIVE						
Coarse Absolute LED Current Drive Range Adjust						
EXTRES = 13K7 ohm +/- 1% over process and temperature.						
Coarse LED Current Full Scale Range with External Reference including absolute and temperature tolerances	ILEDCRE0	LEDIRNG = 00	25		32	mA
	ILEDCRE1	LEDIRNG = 01	30		42.25	mA
	ILEDCRE2	LEDIRNG = 10	40		56.5	mA
	ILEDCRE3	LEDIRNG = 11	50		68	mA
Coarse LED Current Maximum Limit Range	ILEDMAX	LEDIMAX = 0	28		45	mA
	ILEDMAX	LEDIMAX = 1	35		53	mA
FINE LED ABSOLUTE CURRENT DRIVE						
Resolution	ILEDRes			8		bits
Range	ILEDFRan		ILED CRXX			
Zero Current					0	mA
Differential non-linearity	ILEDFDNL	No missing codes	-1		1.15	LSB
Integral non-linearity	ILEFINL				1	LSB
Compliance Voltage ILEDR	ILEDRVC	ILED=50mA	0.75+ AGND		AVDD1 - 0.5V	V
Compliance Voltage ILEDG and ILEDB	ILEDGBVC	ILED=50mA	0.25+ AGND		AVDD1 - 0.5V	V

INPUT VIDEO SAMPLING

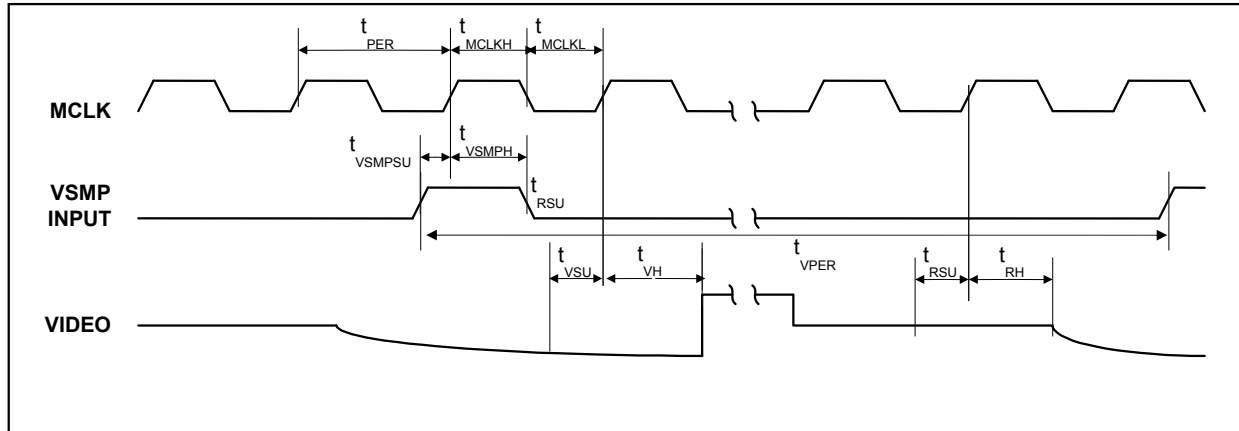

Figure 1 Input Video Timing

Note:

1. See Page 35 (Programmable VSMP Detect Circuit) for video sampling description.

Test Conditions

AVDD1 = 5.75V, DVDD = 3.3V, AGND = DGND = AVDD2 = 0V, $T_A = 25^\circ\text{C}$, MCLK = 24MHz unless otherwise stated.

PARAMETER	SYMBOL	TEST CONDITIONS	MIN	TYP	MAX	UNITS
MCLK period	t_{PER}		41.5			ns
MCLK high period	t_{MCLKH}		25			ns
MCLK low period	t_{MCLKL}		25			ns
VSMP period	t_{VPER}		83			ns
VSMP set-up time	t_{VSMPSU}		6			ns
VSMP hold time	t_{VSMPH}		3			ns
Video level set-up time	t_{VSU}		10			ns
Video level hold time	t_{VH}		3			ns
Reset level set-up time	t_{RSU}		10			ns
Reset level hold time	t_{RH}		3			ns

Notes:

1. t_{VSU} and t_{RSU} denote the set-up time required after the input video signal has settled.
2. Parameters are measured at 50% of the rising/falling edge.

OUTPUT DATA TIMING

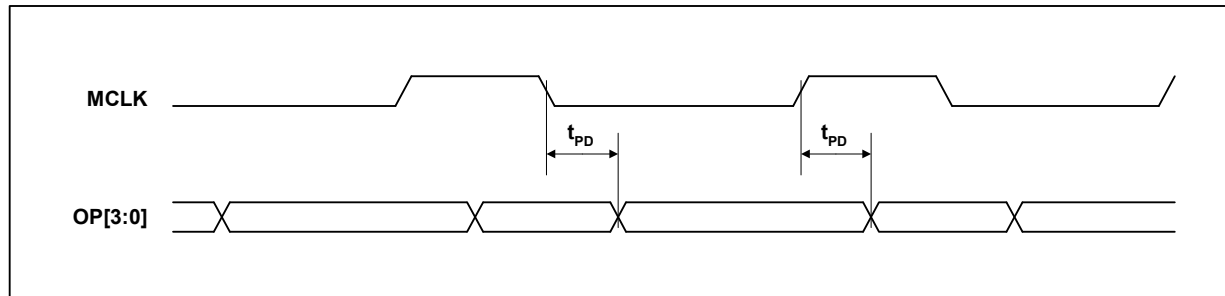

Figure 2 Output Data Timing

Test Conditions

AVDD1 = 5.75V, DVDD = 3.3V, AGND = DGND = AVDD2 = 0V, $T_A = 25^\circ\text{C}$, MCLK = 24MHz unless otherwise stated.

PARAMETER	SYMBOL	TEST CONDITIONS	MIN	TYP	MAX	UNITS
Output propagation delay	t_{PD}	$I_{OH} = 1\text{mA}, I_{OL} = 1\text{mA}$	3	8	15	ns

SERIAL INTERFACE

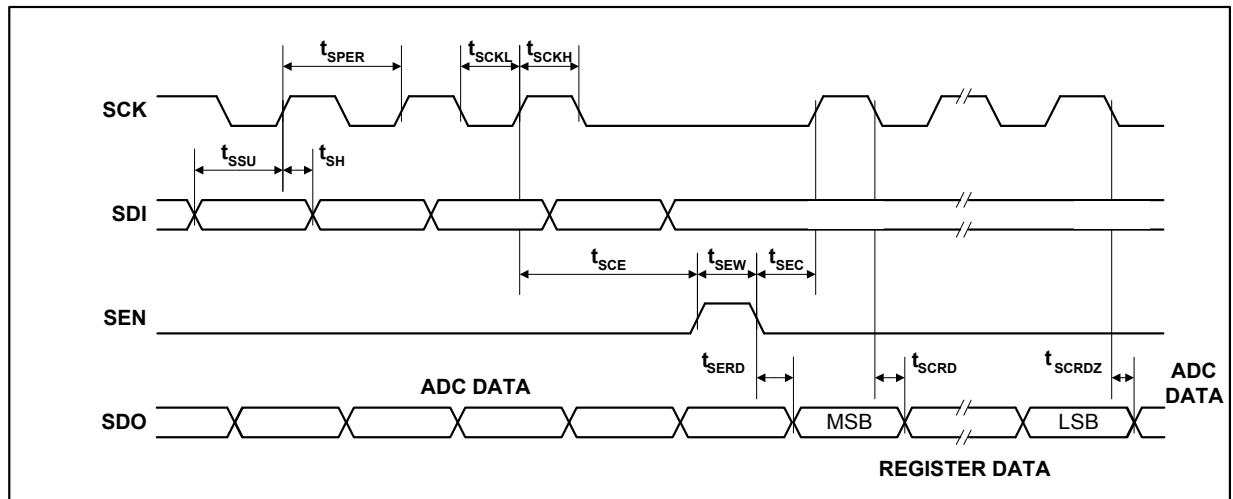

Figure 3 Serial Interface Timing

Test Conditions

AVDD1 = 5.75V, DVDD = 3.3V, AGND = DGND = AVDD2 = 0V, T_A = 25°C, MCLK = 24MHz unless otherwise stated.

PARAMETER	SYMBOL	TEST CONDITIONS	MIN	TYP	MAX	UNITS
SCK period	t_{SPER}		41.6			ns
SCK high	t_{SCKH}		18.8			ns
SCK low	t_{SCKL}		18.8			ns
SDI set-up time	t_{SSU}		6			ns
SDI hold time	t_{SH}		6			ns
SCK to SEN set-up time	t_{SCE}		12			ns
SEN to SCK set-up time	t_{SEC}		12			ns
SEN pulse width	t_{SEW}		25			ns
SEN low to SDO = Register data	t_{SERD}				30	ns
SCK low to SDO = Register data	t_{SCRD}				30	ns
SCK low to SDO = ADC data	t_{SCRDZ}				30	ns

Note:

- Parameters are measured at 50% of the rising/falling edge

PWM TIMING

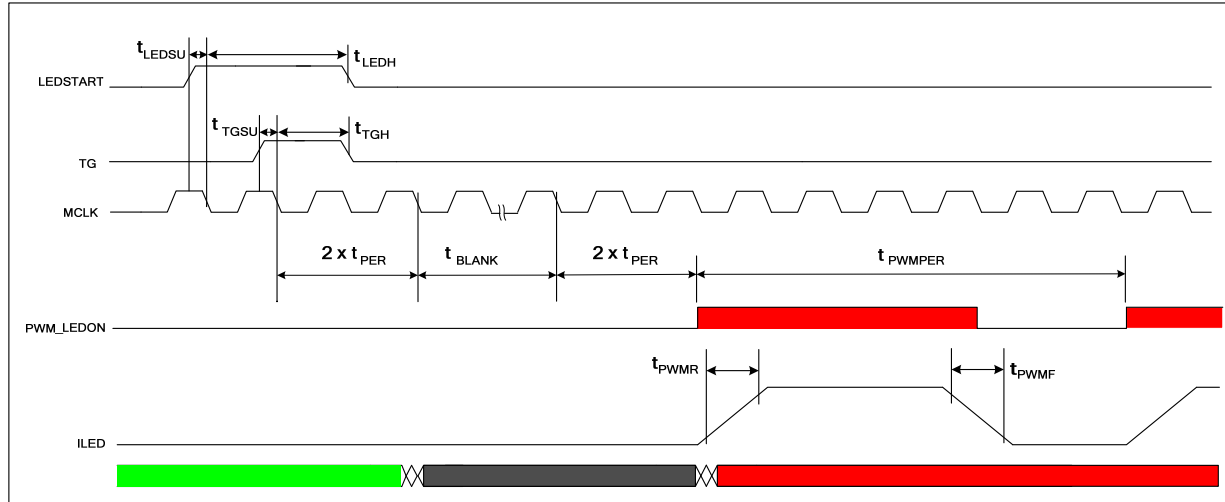

Figure 4 PWM Timing

Test Conditions

AVDD1 = 5.75V, DVDD = 3.3V, AGND = DGND = AVDD2 = 0V, T_A = 25°C, MCLK = 24MHz unless otherwise stated.

PARAMETER	SYMBOL	TEST CONDITIONS	MIN	TYP	MAX	UNITS
PWM LED Current Drive Control						
PWM Period	t _{PWMPER}		(CLKDIV+1) * LEDPWMPER * t _{PER}			ns
PWM Duty Cycle			LEDPWMDC/ LEDPWMPER			-
PWM Period Resolution			(CLKDIV + 1) * t _{PER}			ns
PWM Period Range			(CLKDIV + 1) * 4096 * t _{PER}			ns
PWM Duty Cycle Resolution			(CLKDIV + 1) * t _{PER}			ns
PWM Duty Cycle Range			(CLKDIV + 1) * 4096 * t _{PER}			ns
PWM Enable Coarse Adjust	t _{PWMMaxCount}		t _{PWMPER} * 1		t _{PWMPER} * 128	ns
LEDSTART set-up time	T _{LEDSU}		6			ns
LEDSTART hold time	T _{LEDH}		3			ns
TG set-up time	t _{TGSU}		6			ns
TG hold time	t _{TGH}		3			ns
PWM Rise / Fall Time	t _{PWMR} / t _{PWMF}		1		5	us
Minimum blank period	t _{BLANK}		25			us

Notes:

1. For LED Current Drive Description refer to Page 17.
2. The Blank period starts on the 2nd falling edge of MCLK after TG goes high.
3. CLKDIV, LEDPWMPER and LEDPWMDC are register settings. For further details see Table 10.

DEVICE DESCRIPTION

INTRODUCTION

A block diagram of the device showing the signal path is presented on Page 1.

The WM8255 processes the sampled video signal on VINP with respect to the video-reset level or an internally/externally generated reference level through the analogue-processing channel.

This processing channel consists of an Input Sampling block with optional Reset Level Clamping (RLC) and Correlated Double Sampling (CDS), an 8-bit programmable offset DAC and an 8-bit Programmable Gain Amplifier (PGA).

The ADC then converts each resulting analogue signal to a 16-bit digital word. The digital output from the ADC is presented on a 4-bit wide bus.

On-chip control registers determine the configuration of the device, including the offsets and gains applied to each channel. These registers are programmable via a serial interface.

The device can control the brightness and timing of the Red, Green and Blue LEDs used in a CIS sensor. This is controlled via the serial control interface and external timing pins.

INPUT SAMPLING

The WM8255 has a single analogue processing channel and ADC, which can be used in a flexible manner to process both monochrome and line-by-line colour inputs.

Monochrome: The selected input (VINP) is sampled, processed by the analogue channel, and converted by the ADC. The same offset DAC and PGA register values are always applied.

Colour Line-by-Line: VINP is sampled and processed by the analogue channel before being converted by the ADC. The gains and offset register values applied to the PGA and offset DAC can be switched between the independent Red, Green and Blue digital registers (e.g. Red → Green → Blue → Red...) at the start of each line in order to facilitate line-by-line colour operation. The INTM[1:0] bits determine which register contents are applied (see Table 1) to the PGA and offset DAC. By using the INTM[1:0] bits to select the desired register values only one register write is required at the start of each new colour line.

RESET LEVEL CLAMPING (RLC)

To ensure that the signal applied to the WM8255 VINP pin lies within the valid input range (0V to AVDD) the CCD output signal is usually level shifted by coupling through a capacitor, C_{IN} . When active, the RLC circuit clamps the WM8255 side of this capacitor to a suitable voltage during the CCD reset period. The RLCINT register bit controls is used to activate the Reset Level Clamp circuit.

A typical input configuration is shown in Figure 5. The Timing Control Block generates a clamp pulse, CL, from MCLK and VSMP (when RLCINT is high). When CL is active the voltage on the WM8255 side of C_{IN} , at VINP, is forced to the VRFC/VBIAS voltage (V_{VRLC}) by switch 1. When the CL pulse turns off, the voltage at VINP initially remains at V_{VRLC} but any subsequent variation in sensor voltage (from reset to video level) will couple through C_{IN} to VINP.

RLC is compatible with both CDS and non-CDS operating modes, as selected by switch 2. Refer to the CDS/non-CDS Processing section.

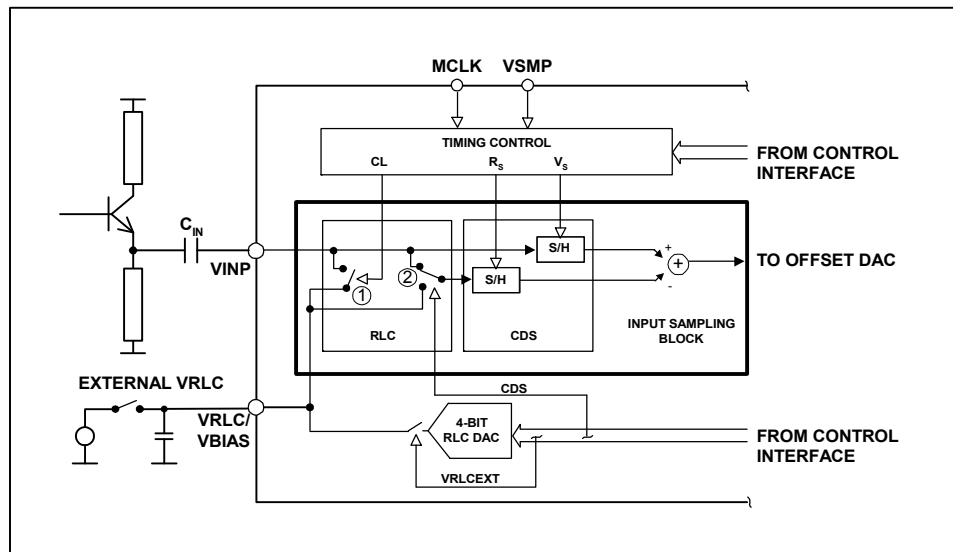

Figure 5 Reset Level Clamping and CDS Circuitry

Reset Level Clamping is controlled by register bit RLCINT. Figure 6 illustrates the effect of the RLCINT bit for a typical CCD waveform, with CL applied during the reset period.

The RLCINT register bit is sampled on the positive edge of MCLK that occurs during each VSMP pulse. The sampled level, high (or low) controls the presence (or absence) of the internal CL pulse on the next reset level. The position of CL can be adjusted by using control bits CDSREF[1:0]

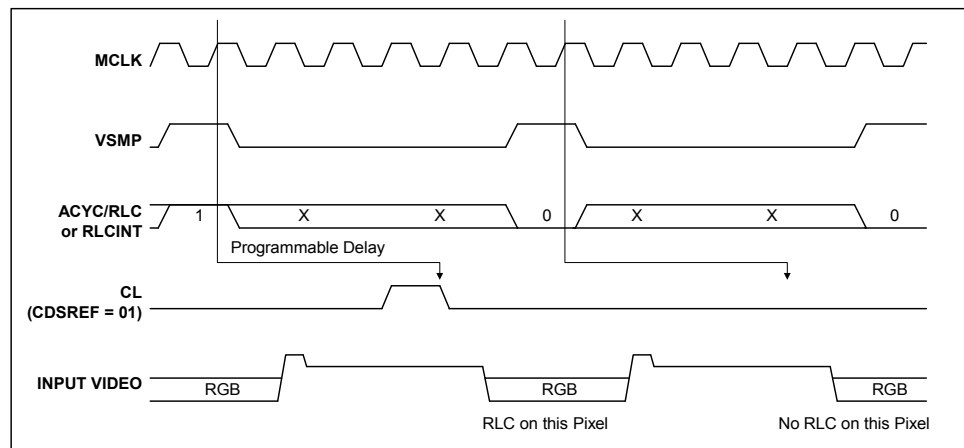

Figure 6 Relationship of RLCINT, MCLK and VSMP to Internal Clamp Pulse, CL

The VRLC/VBIAS pin can be driven internally by a 4-bit DAC (RLCDAC) by writing to control bits RLCV[3:0]. The RLCDAC range and step size may be increased by writing to control bit RLCDACRNG. Alternatively, the VRLC/VBIAS pin can be driven externally by writing to control bit VRLCEXT to disable the RLCDAC and then applying a d.c. voltage to the pin.

CDS/NON-CDS PROCESSING

For CCD type input signals, the signal may be processed using CDS, which will remove pixel-by-pixel common mode noise. For CDS operation, the video level is processed with respect to the video reset level, regardless of whether RLC has been performed. To sample using CDS, control bit CDS must be set to 1 (default), this controls switch 2 (Figure 5) and causes the signal reference to come from the video reset level. The time at which the reset level is sampled, by clock R_s/CL , is adjustable by programming control bits CDSREF[1:0].

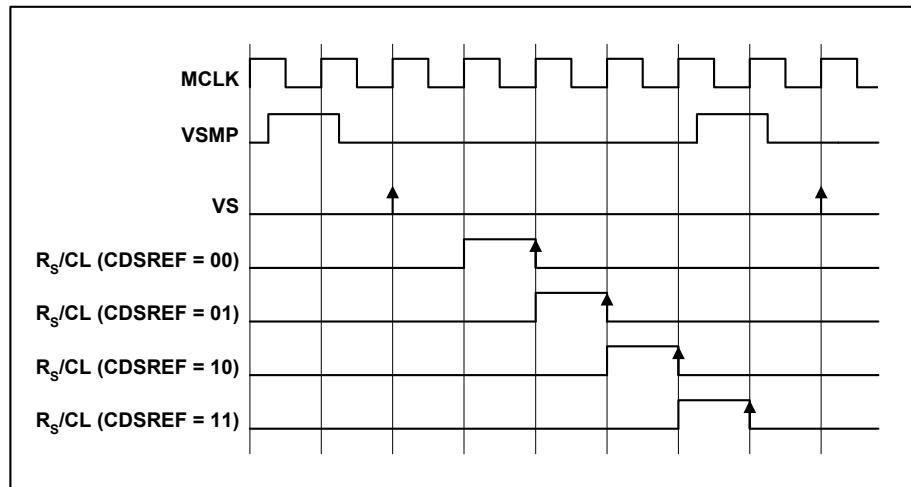

Figure 7 Reset Sample and Clamp Timing

For CIS type sensor signals, non-CDS processing is used. In this case, the video level is processed with respect to the voltage on pin VRLC/BIAS, generated internally or externally as described above. The VRLC/BIAS pin is sampled by R_s at the same time as V_s samples the video level in this mode.

OFFSET ADJUST AND PROGRAMMABLE GAIN

The output from the CDS block is a differential signal, which is added to the output of an 8-bit Offset DAC to compensate for offsets and then amplified by an 8-bit PGA. The gain and offset can be set for each of three colours by writing to control bits DACx[7:0] and PGAx[7:0] (where x can be R, G or B).

In colour line-by-line mode the gain and offset coefficients that are applied to the PGA and offset DAC can be multiplexed by control of the INTM[1:0] bits as shown in Table 1.

INTM[1:0]	DESCRIPTION
00	Red offset and gain registers are applied to offset DAC and PGA (DACR[7:0] and PGAR[7:0])
01	Green offset and gain registers applied to offset DAC and PGA (DACG[7:0] and PGAG[7:0])
10	Blue offset and gain registers applied to offset DAC and PGA (DACB[7:0] and PGAB[7:0])
11	Reserved.

Table 1 Offset DAC and PGA Register Control

The gain characteristic of the WM8255 PGA is shown in Figure 8. Figure 9 shows the maximum input voltage (at VINP) that can be gained up to match the ADC full-scale input range (2.0V).

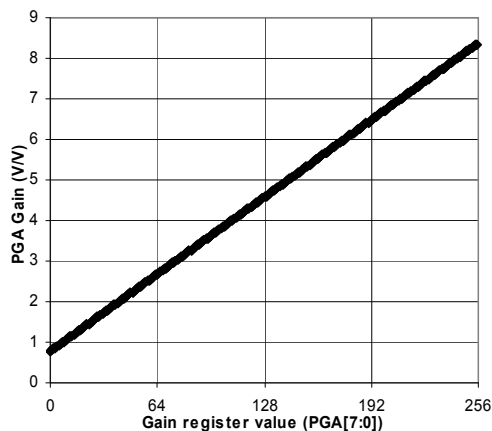

Figure 8 PGA Gain Characteristic

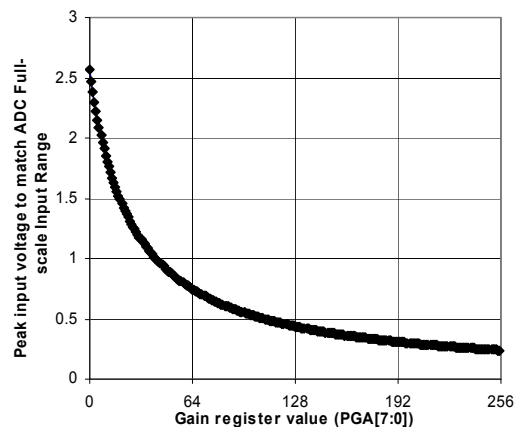

Figure 9 Peak Input Voltage to Match ADC Full-scale Range

ADC INPUT BLACK LEVEL ADJUST

The output from the PGA should be offset to match the full-scale range of the ADC ($V_{FS} = 2.0V$). For negative-going input video signals, a black level (zero differential) output from the PGA should be offset to the top of the ADC range by setting register bits PGAFS[1:0]=10. For positive going input signal the black level should be offset to the bottom of the ADC range by setting PGAFS[1:0]=11. Bipolar input video is accommodated by setting PGAFS[1:0]=00 or PGAFS[1:0]=01 (zero differential input voltage gives mid-range ADC output).

OVERALL SIGNAL FLOW SUMMARY

Figure 10 represents the processing of the video signal through the WM8255.

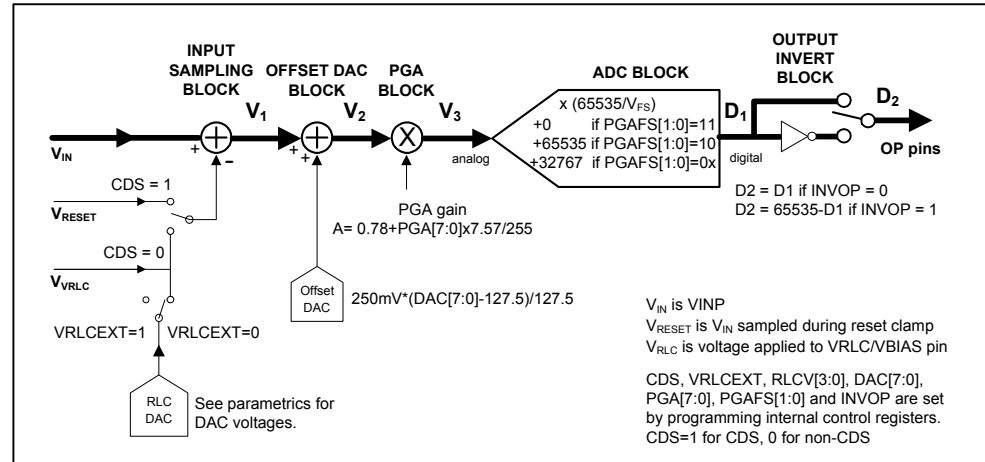

Figure 10 Overall Signal Flow

The **INPUT SAMPLING BLOCK** produces an effective input voltage V_1 . For CDS, this is the difference between the input video level V_{IN} and the input reset level V_{RESET} . For non-CDS this is the difference between the input video level V_{IN} and the voltage on the VRLC/VBIAS pin, V_{VRLC} , optionally set via the RLC DAC.

The **OFFSET DAC BLOCK** then adds the amount of fine offset adjustment required to move the black level of the input signal towards 0V, producing V_2 .

The **PGA BLOCK** then amplifies the white level of the input signal to maximise the ADC range, outputting voltage V_3 .

The **ADC BLOCK** then converts the analogue signal, V_3 , to a 16-bit unsigned digital output, D_1 .

The digital output is then inverted, if required, through the **OUTPUT INVERT BLOCK** to produce D_2 .

CALCULATING OUTPUT FOR ANY GIVEN INPUT

The following equations describe the processing of the video and reset level signals through the WM8255.

INPUT SAMPLING BLOCK: INPUT SAMPLING AND REFERENCING

If $CDS = 1$, (i.e. CDS operation) the previously sampled reset level, V_{RESET} , is subtracted from the input video.

$$V_1 = V_{IN} - V_{RESET} \quad \text{Eqn. 1}$$

If $CDS = 0$, (non-CDS operation) the simultaneously sampled voltage on pin VRLC is subtracted instead.

$$V_1 = V_{IN} - V_{VRLC} \quad \text{Eqn. 2}$$

If $VRLCEXT = 1$, V_{VRLC} is an externally applied voltage on pin VRLC/VBIAS.

If $VRLCEXT = 0$, V_{VRLC} is the output from the internal RLC DAC.

$$V_{VRLC} = (V_{RLCSTEP} \cdot RLCV[3:0]) + V_{RLCBOT} \quad \text{Eqn. 3}$$

$V_{RLCSTEP}$ is the step size of the RLC DAC and V_{RLCBOT} is the minimum output of the RLC DAC.

OFFSET DAC BLOCK: OFFSET (BLACK-LEVEL) ADJUST

The resultant signal V_1 is added to the Offset DAC output.

$$V_2 = V_1 + \{250\text{mV} * (\text{DAC}[7:0] - 127.5)\} / 127.5 \quad \text{Eqn. 4}$$

PGA NODE: GAIN ADJUST

The signal is then multiplied by the PGA gain,

$$V_3 = V_2 * [0.78 + (\text{PGA}[7:0] * 7.57) / 255] \quad \text{Eqn. 5}$$

ADC BLOCK: ANALOGUE-DIGITAL CONVERSION

The analogue signal is then converted to a 16-bit unsigned number, with input range configured by $\text{PGA}[7:0]$.

$$D_1[15:0] = \text{INT}\{ (V_3 / V_{FS}) * 65535\} + 32767 \quad \text{PGA}[7:0] = 00 \text{ or } 01 \quad \text{Eqn. 6}$$

$$D_1[15:0] = \text{INT}\{ (V_3 / V_{FS}) * 65535\} \quad \text{PGA}[7:0] = 11 \quad \text{Eqn. 7}$$

$$D_1[15:0] = \text{INT}\{ (V_3 / V_{FS}) * 65535\} + 65535 \quad \text{PGA}[7:0] = 10 \quad \text{Eqn. 8}$$

where the ADC full-scale range, $V_{FS} = 2.0\text{V}$

$$\text{if } D_1[15:0] < 0 \quad D_1[15:0] = 0$$

$$\text{if } D_1[15:0] > 65535 \quad D_1[15:0] = 65535$$

OUTPUT INVERT BLOCK: POLARITY ADJUST

The polarity of the digital output may be inverted by control bit INVOP .

$$D_2[15:0] = D_1[15:0] \quad (\text{INVOP} = 0) \quad \text{Eqn. 9}$$

$$D_2[15:0] = 65535 - D_1[15:0] \quad (\text{INVOP} = 1) \quad \text{Eqn. 10}$$

OUTPUT FORMATS

The digital data output from the ADC is available in a 4-bit wide multiplexed. Latency of valid output data with respect to VSMP is programmable by writing to control bits DEL[1:0]. The latency is shown in the Operating Mode Timing Diagrams section.

Figure 11 shows the output data formats for all modes. Table 2 summarises the output data obtained for each format.

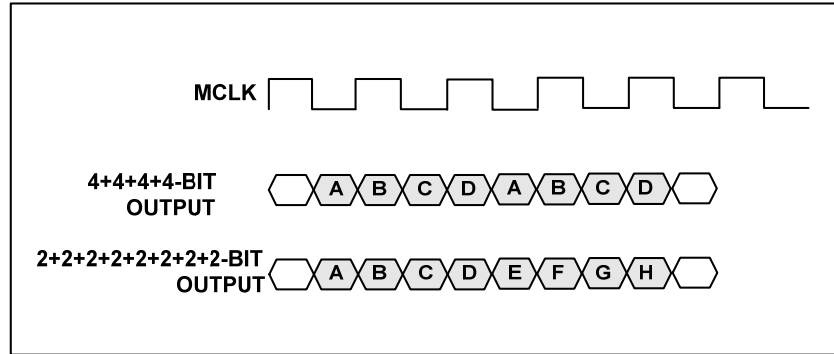

Figure 11 Output Data Formats (4 bit - Modes 1 & 3, 2 bit – Mode 1)

OUTPUT FORMAT	OUTPUT PINS	OUTPUT
4+4+4+4-bit (nibble)	OP[3:0]	A = d15, d14, d13, d12 B = d11, d10, d9, d8 C = d7, d6, d5, d4 D = d3, d2, d1, d0
2+2+2+2+2+2+2+2-bit	OP[1:0]	A = d15, d14 B = d13, d12 C = d11, d10 D = d9, d8 E = d7, d6 F = d5, d4 G = d3, d2 H = d1, d0

Table 2 Details of Output Data Shown in Figure 11

LED CURRENT DRIVE CONTROL

The WM8255 allows the user to control:

- the sequence of illumination
- the period of illumination
- the intensity of illumination

of the red, blue and green LEDs used to illuminate the image during a scan.

A sequence state machine is used to progress the sequence and control the duration of the LED selection. The progression of the sequence state machine is dependent on whether the WM8255 is in colour mode or monochromatic mode. The intensity of illumination is controlled on either control of the LED drive current or pulsing of the LED driving current.

LED CURRENT DRIVE SEQUENCE CONTROL

With reference to Figure 12, the WM8255 uses a LED sequence state machine to control the sequence and duration of the illumination of the red, green and blue LEDs.

The LED sequence state machine can progress through up to 4 states each sequence. Each of the sequence states (STATE_0 to STATE_3) may be set to one of four values to determine on whether a red, green or blue LED is illuminated or all LEDs are off. The register STATERST will determine the number of states the sequence state machine can progress through. Once the sequence state machine has reached the reset state, the LED state machine will remain in this state until again initiated.

LED CURRENT DRIVE SEQUENCE DEFINITION

Figure 13 illustrates the functionality of the sequence state mapping. The current state of the sequence machine (SEQ_STATE) is an internal register used to select one of the four register state mappings. This register increments until the value specified by STATERST at which point the sequence will hold. Figure 14 shows two examples when STATERST is set to “11_{bin}” for a 4 state sequence, and to “01_{bin}” for a 2 state sequence.

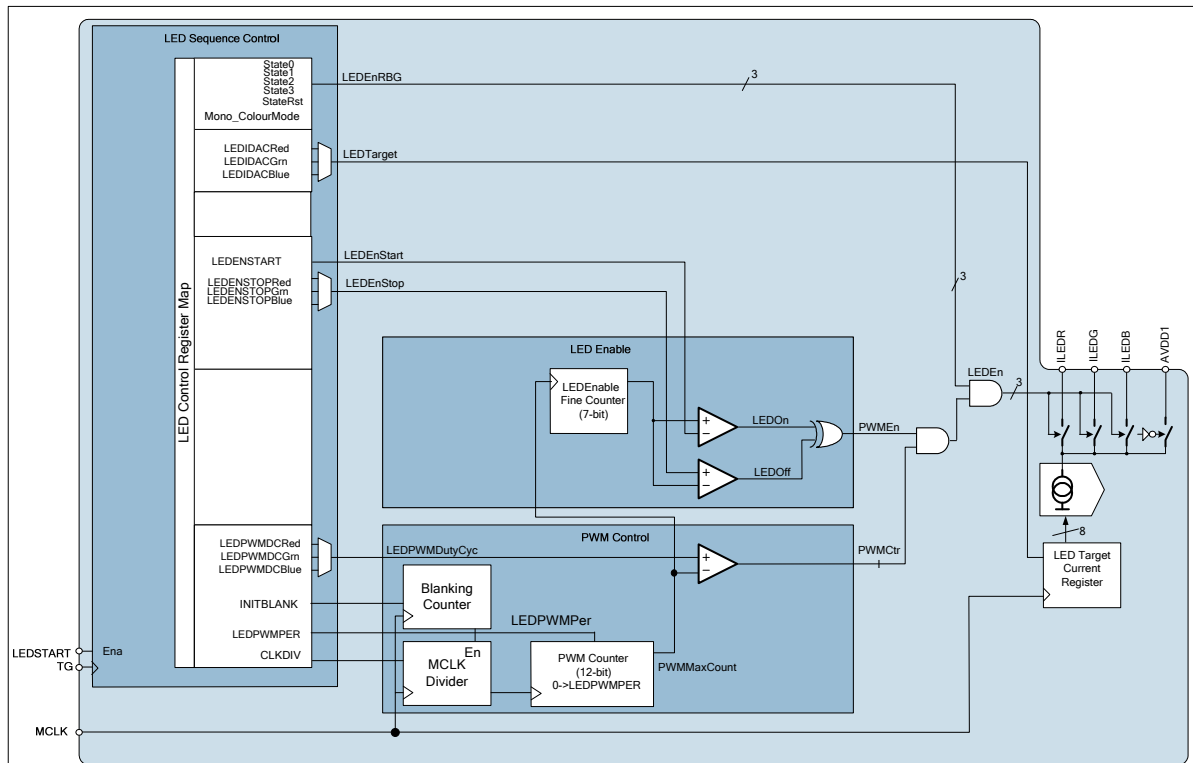

Figure 12 Block Diagram of PWM LED Control

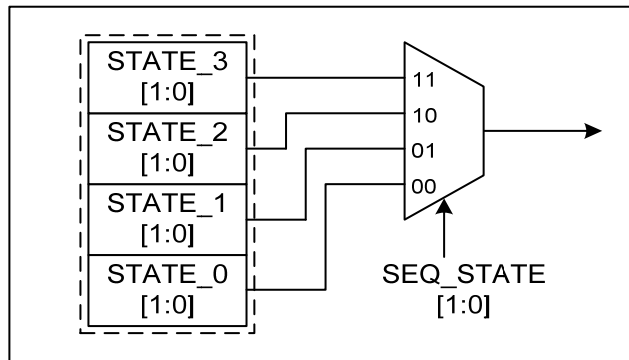

Figure 13 State Mapping Functionality



Figure 14 Setting the Sequence Length with STATERST

LED CURRENT DRIVE SEQUENCE SYNCHRONISATION AND PROGRESSION

The trigger to progress the state machine through the sequence states is dependent on whether the LED driver is operating in colour mode or monochrome mode.

COLOUR MODE

In Colour Mode operation, LEDSTART and TG are used to synchronise and progress the sequence state machine. This allows a single LED change for each line scan.

With both LEDSTART and TG high, the sequence state machine is synchronously set to STATE_0 by MCLK. With LEDSTART low and at the next high pulse of TG, the sequence state machine is progressed to the next state, STATE_1, by MCLK. This is repeated until the maximum number of states determined by STATERST has been reached. At this point the LED drive current will be switched away from the selected LED. The sequence state machine will be held in this state until restarted by LEDSTART and TG.

If at any time both TG and LEDSTART are high, the sequence is synchronously set back to STATE_0 by MCLK.

MONOCHROME (COMPOSITE) MODE

In Monochrome Mode, the progression between sequence states is triggered by the completion of the previous sequence state. This allows a complete LED sequence change for each line scan.

With both TG and LEDSTART high, the sequence state machine is synchronously set to the STATE_0 by MCLK. When the STATE_0 has reached the end of its enable period, the sequence state machine is progressed to the next state by MCLK. This is repeated until the maximum number of states determined by STATERST has been reached. At this point the LED drive current will be switched away from the selected LEDs. The sequence state machine will be held in this state until restarted by LEDSTART and TG.

If at any time both TG and LEDSTART are high, the sequence is synchronously set back to STATE_0 by MCLK.

LED CURRENT DRIVE INTENSITY CONTROL

The LED current driver is programmable to allow the LED light intensity to be adjusted independent of the LED light wavelength. Two methods are available for this:

- The absolute LED current drive may be set using a programmable 8-bit current DAC. The current DAC range for each of the LEDs may be adjusted to one of four ranges using the register LEDIRNG.
- The LED current drive may be pulsed using a pulse width modulated. The pulse width modulated period is set using the register LEDPWMPER and on time using the registers LEDPWMDCR, LEDPWMDCB and LEDPWMDCG.

Control of the absolute LED current drive and PWM modulation are independently programmable for each of the red, green and blue LEDs using the register map. The signals LEDSTART, TG and MCLK determine timing.

LED CURRENT DRIVE STATE TRANSITION AND PWM SWITCHING

The WM8255 is the combination of a LED current switching matrix and an AFE. With reference to Figure 15, during a typical line scan the video signal of the previous line scan is digitised by the AFE while the image of the current line scan is illuminated. To suppress any switching noise of the LED switching matrix coupling into the AFE, care is taken while switching the current.

Two types of current switching are available in the WM8255, state transition switching and PWM switching. State transition switching occurs when either a new LED is to be selected or the LED current DAC has to be updated. PWM transition switching occurs when the illumination intensity is controlled by pulsing the LED drive current. In colour mode, state transition switching should occur at the start of a line scan. In mono mode, state transition switching can occur during the line scan. In either colour mode or mono mode, PWM transition switching can occur during the line scan.

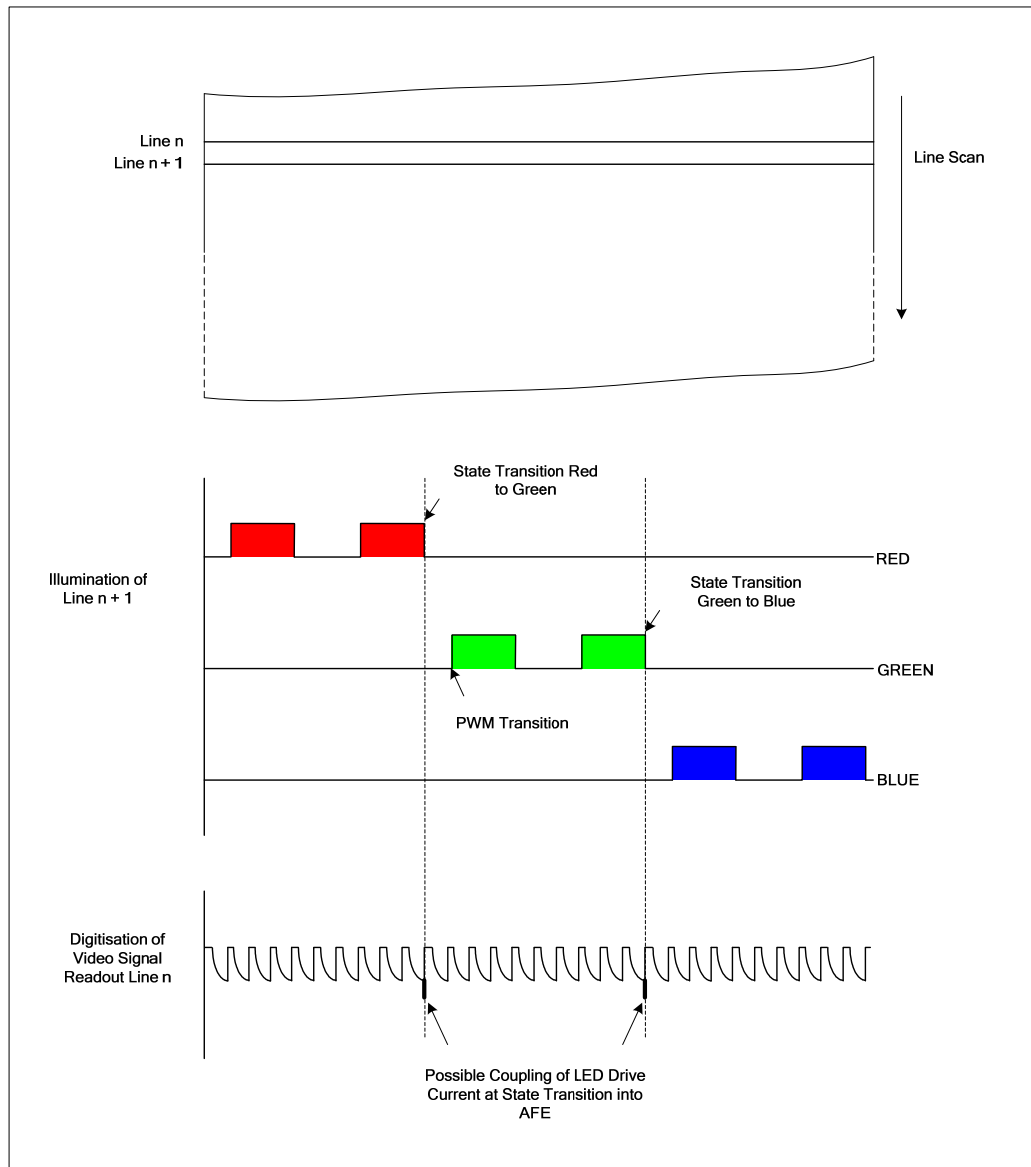

Figure 15 Relationship between Line Scan Illumination and Video Signal Readout

Two current switching techniques are used for state and PWM transition switching, slew rate controlled current switching and current steering switching.

With reference to Figure 16, the LED drive current has three blocks, the LED current DAC, the LED RGB matrix switch and a shunt current path switch.

With reference to Figure 16, for current slew rate controlled switching, the LED current DAC value is reset from the current value to zero then set to an updated value. Slew rate limited current switch may be partitioned into four operations:

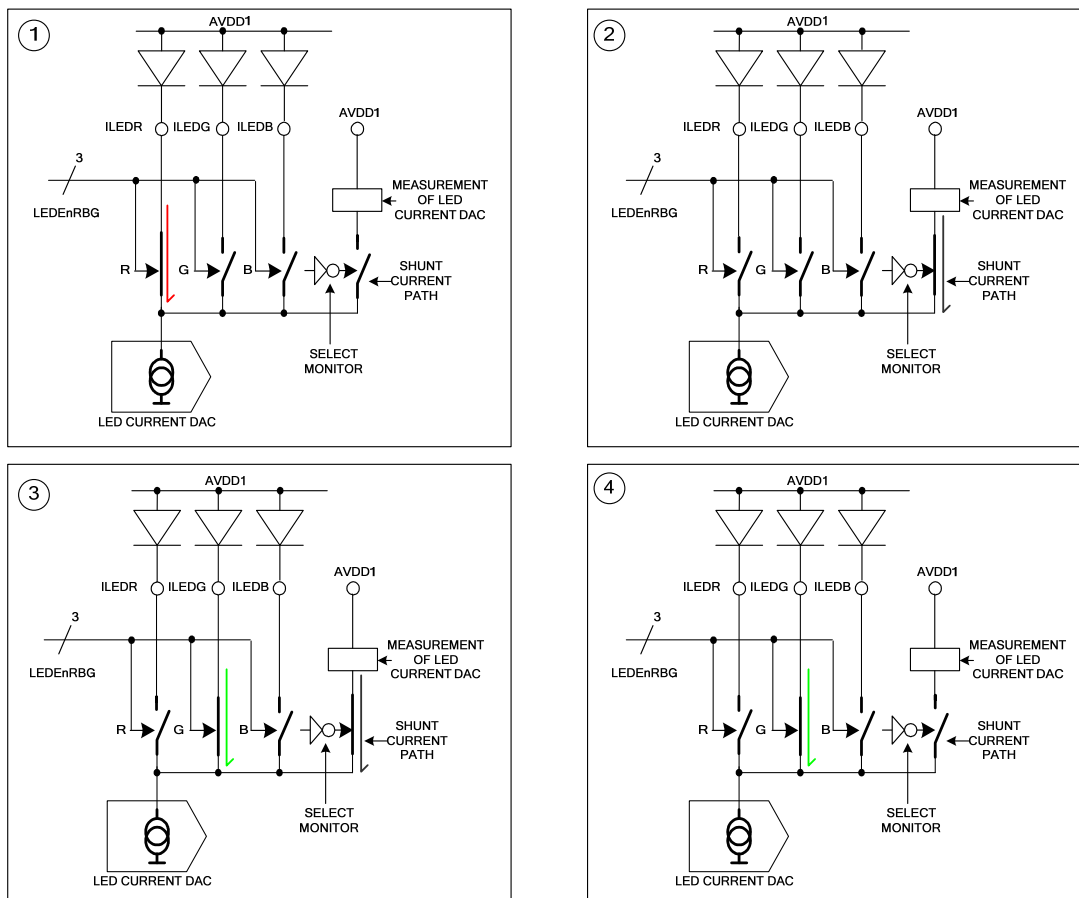

Figure 16 Current Slew Rate Controlled Switching

1. The red RGB switch is initially closed and the LED drive current will flow in the red diode
2. The Red RGB switch will open and the shunt current path switch is closed. The LED drive current will flow in the shunt current path. During this period the LED current DAC is reset to zero then updated to the next value. No current will flow in any LEDs.
3. The green RGB switch will be closed.
4. The auxiliary current path switch will be opened and LED drive current will flow in the green LED.

The finite time taken for a slew rate controlled current switch is the period necessary to change the value of the LED current DAC. The slew rate of the current change is limited by the dynamic performance of the LED current DAC. During this time the LED IDAC current will flow through the shunt current path switch and no illumination will occur. This period of time is defined by blanking period

MONO MODE REQUIREMENTS

During a slew rate limited current switch of the LED IDAC, the change of current flowing in the IDAC will couple a minor disturbance into the AFE. In colour mode this disturbance is not an issue since the state change switching will occur at the beginning of a line scan when no imaging is occurring. In mono mode a red, blue and green state switching may occur during a line scan and couple correlated switching noise into the signal path.

In mono mode to minimise switching noise into the signal path::

- The blanking period must be disabled. In this mode during a state change, no slew rate limiting switching will occur, Only the RGB switches will be switched. Table 3 defines the method to disable blanking during a state transition.
- In this mode of operation, between states the absolute value of the LED IDAC current must not change.

- In this mode of operation, setting the duty cycle to zero is an invalid state. The RGB switches should be used to switch off the LED current.

This method will have no effect on colour mode performance.

BLANKING DISABLE CODE SET		
Address	Data	Comment
0x01	0xA3	This will put the part into test configuration mode. Any address will now point to the extended page reconfiguration register
0x24	0x1C	This will: -- force the LED IDAC control state machine to stay on at all time - force the value to be held in LEDIDACR to be loaded into the LED current DAC
0x01	0x23	This will take the part back into normal operating mode.
Notes:		
1. If this COMPLETE SEQUENCE of operation is not carried out TOGETHER the part may go into an unsupported mode		
To finish a mono mode scan with blanking period disabled and perform another operation, the part needs to get into a know state. Two options are available for a complete reset of the device or a reset of the LED sequence controller:		
Option 1: WM8255 global reset from blanking period disable		
Address	Data	Comment
0x04	0x00	This will reset the WM8255 into its default condition. The part should now be fully reconfigured into the user configuration.
Option 2: WM8255 LED sequence controller reset from blanking period disable		
Address	Data	Comment
0x2F	0x00	This will reset LED sequence controller WM8255. All configuration data will be held.

Table 3 Blanking Period Disable

With reference to Figure 17 for current steering,

1. The appropriate RGB matrix switch is closed allowing the LED current DAC current to flow in the LED
2. The first step to switch off the LED current is to close the shunt current path switch
3. The LED is switched off by opening the RGB switch matrix.
4. To switch on the LED, first the shunt current path switch is closed and the cycle repeats.

A make before break switch sequence is used when the LED is switched on or off. As a result the LED current DAC always has a path to flow and never changes value.

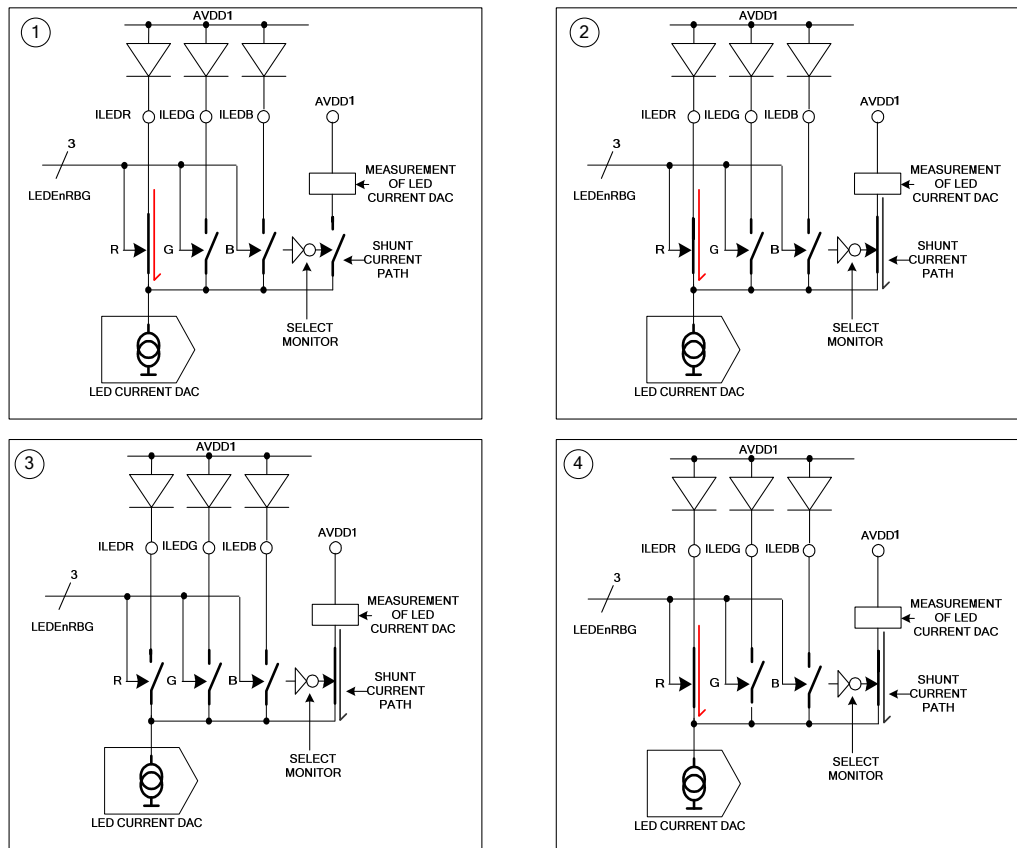

Figure 17 Current Steering Switching

LED CURRENT DRIVE CURRENT PWM CONTROL

During each sequence state, the LED control module can be pulsed by Pulse Width Modulating (PWM) the LED current drive. For each sequence state, the PWM frequency, duty cycle, and number of PWM cycles can be configured.

The PWM controller consists of two blocks; the MCLK divider and the PWM counter. The MCLK divider divides the MCLK by an amount set by the register CLKDIV.

The divided MCLK is then used to clock the PWM counter. The PWM counter will increment until it reaches its maximum count set by the register LEDPWMPER. At this point, the PWM counter will reset to zero, then continue to increment. This will set the period of the PWM control.

As the PWM counter is incremented, its state is compared with the duty cycle setting, which is set by the value in register LEDPWMDC. PWMCtrl is set while the counter value is smaller than the duty cycle setting. When the counter is larger than or equal to the duty cycle, PWMCTRL is reset for the rest of the PWM period. This will set the duty cycle of the PWM control.

The reset of the PWM counter will increment the LEDEnable counter. When the LEDEnable counter has reached LEDENSTART, PWMEn is set high, which allows PWMCtrl to control the LED current drive. The LEDEnable counter will continue to increment until it has reached LEDENSTOP. At this point PWMEn is set low, which stops PWMCtrl from controlling the LED current drive. This will set the number of cycles of the PWM control.

The PWM frequency is defined by LEDPWMPER and the divider CLKDIV. LEDPWMPER and CLKDIV may be calculated as the nearest integral of the MCLK frequency divided by the PWM frequency. If the maximum value of LEDPWMPER would reach its maximum before the desired PWM period is achieved, CLKDIV should be incremented to scale LEDPWMPER correctly.

The PWM duty cycle is defined by LEDPWMDC and CLKDIV. For a chosen PWM frequency, an integral number of PWM cycles for the period of TG may be calculated. The range of the PWM period and the duty cycle can be up to $(2^4 \times 2^{12})$ MCLK cycles.

There is an operational difference in monochrome mode in that LEDENSTART is only used in the first state. In subsequent states the LED enable is always activated after the appropriate number of blanking periods (LEDENSTOP is used in the same method as colour mode operation).

NON PWM MODE

The PWM functionality can be disabled and just the current DAC can be used. The duty cycle LEDPWMDC register for each colour should be set to equal the duty cycle period register, LEDPWMPER. The value of both these registers should be set to an appropriate value.

LED CURRENT DRIVE CURRENT BLANKING PERIOD

At the start of a LED sequence state transition the LED controller performs a blanking period. The blanking period is a period of time reserved to switch to the next LED drive current state in the sequence. In addition, during the blanking period the absolute LED drive current will be updated, a Safe Operating Area (SOA) test may be performed and finally the next LED in the sequence will be selected then driven. At completion of the blanking period, the PWM controller is enabled.

Figure 18 shows a basic blanking period during a state transition of switching the Red LED off, then Green LED on.

The blanking period may be split into a sequence of five operations:

1. The Red RGB switch will be switched off and any current forced to flow in the shunt current path.
2. The LED current DAC will be disabled. During this period, the current flow in the auxiliary current path will tend to zero.
3. The LED current DAC value will be updated to the value necessary to drive the Green LED. During this time, the current flow in the auxiliary current path will tend to the updated LED current DAC current.
4. A SOA test will be performed on the updated LED current DAC current.
5. The Green RGB switch will be switched on.

The transition from one state to the next takes the finite time defined by the period t_{blank} .

With reference to Table 4, the basic blanking period may be optimised dependant on the mode of operation.

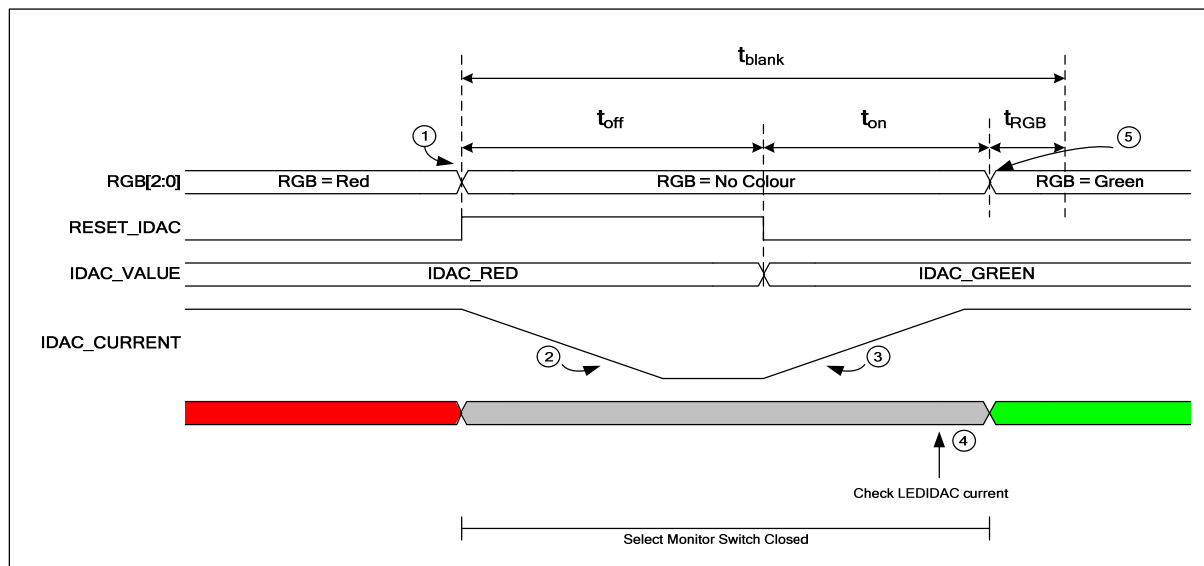

Figure 18 LED Current DAC Current during a Blanking Period

ILIMITEN [1:0]	DESCRIPTION
00	At a state transition, one blanking period will be used before the LED can be enabled. LED DAC current will be changed and next LED in sequence shall be selected. No Safe Operating Area test will be performed.
01	At a state transition, two blanking periods will be used before the LED can be enabled. During the first blanking period, should the LED DAC current exceed LEDIMAX, ILIMITFLAG is set and the LED DAC current is reduced by the percentage set by ILIMITDEC. During the second blanking period, should the LED current exceed LEDIMAX, ILIMITFLAG is set and the LED DAC current will be shutdown.
10	At a state transition, one blanking period will be used before the LED can be enabled. Should the LED current exceed LEDIMAX, ILIMITFLAG is set. The LED current will not be reduced automatically. In this situation, the user should take measures to protect the LED by reducing the LED current.
11	Not a valid setting

Table 4 Modes of Operation of ILIMITEN Register

SETTING THE INITBLANK REGISTER

With reference to Figure 19, the period t_{BLANK} is the initial blank period with no illumination. The initial blank period time must be controlled by setting a value for a 9-bit register INITBLANK. Setting this register will enable a counter that is clocked by MCLK to allow for the necessary minimum 25 microseconds. The last three LSBs are fixed to zero and only the 6 MSBs are adjustable.

The value needed for the register INITBLANK is calculated by :-

$(t_{BLANK} * 0.8) / \text{MCLK period} = \text{INITBLANK}_{dec}$. This number should be rounded up to an integral decimal number.

The binary equivalent of INITBLANK_{dec} should be calculated and, making sure the last 3 LSBs are zero, should be set in the register.

For example:-

$\text{MCLK} = 24 \text{ Mhz} \Rightarrow 41.6\text{ns} (t_{PER})$

$(t_{BLANK} * 0.8) / t_{PER} = (25\mu\text{s} * 0.8) / 41.6\text{ns} = 480.77$

The nearest integral number where the binary equivalent has zero values in the last 3 LSBs is 480.

$480 = 111100000$ bin. Therefore the 6 MSBs to be set to the register INITBLANK are:- 111100

By default INITBLANK is set to zero which sets the initial blank period to equal the PWM period/0.8 set by LEDPWMPER.

If ILIMITEN is set to '01' then this blanking period will be doubled. Note that the INITBLANK register value does not require a new value in this situation.

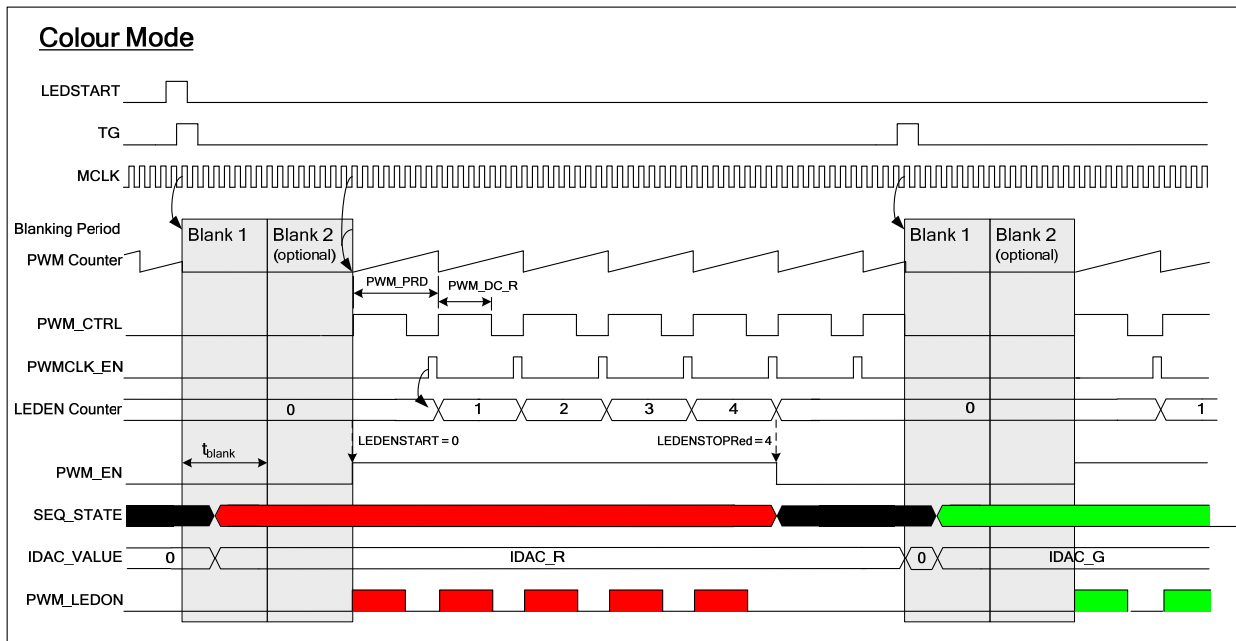

Figure 19 PWMLED Current Control Timing, CLKDIV = 0 – RGB Colour Scan

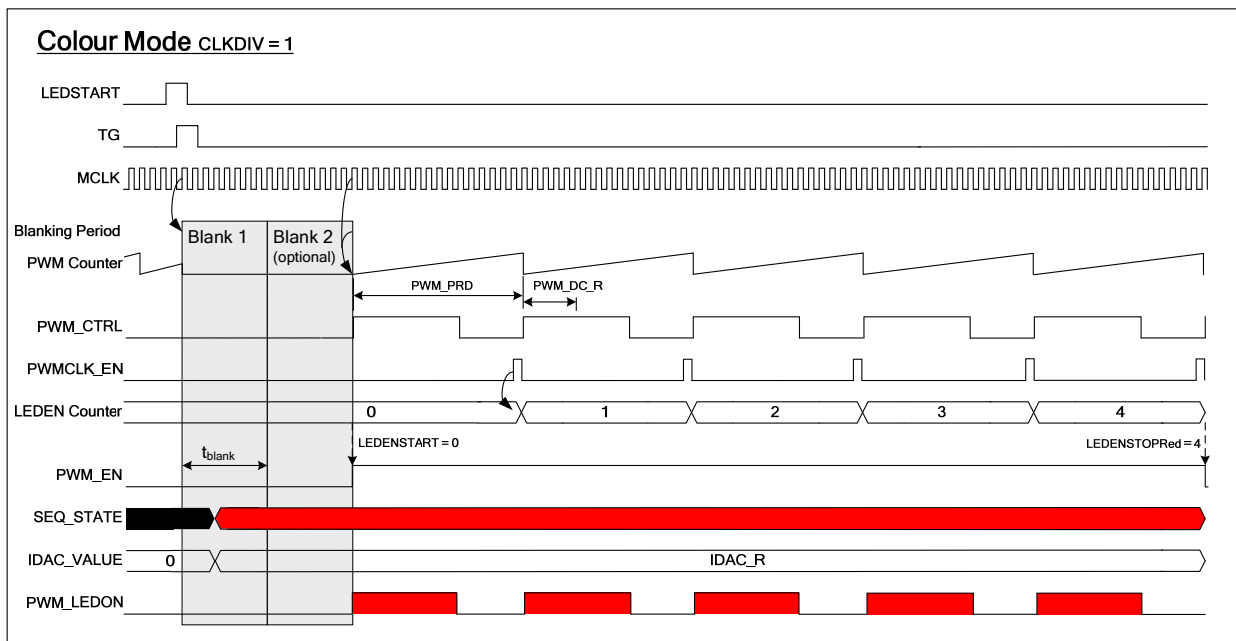

Figure 20 PWMLED Current Control Timing, CLKDIV = 1 – RGB Colour Scan

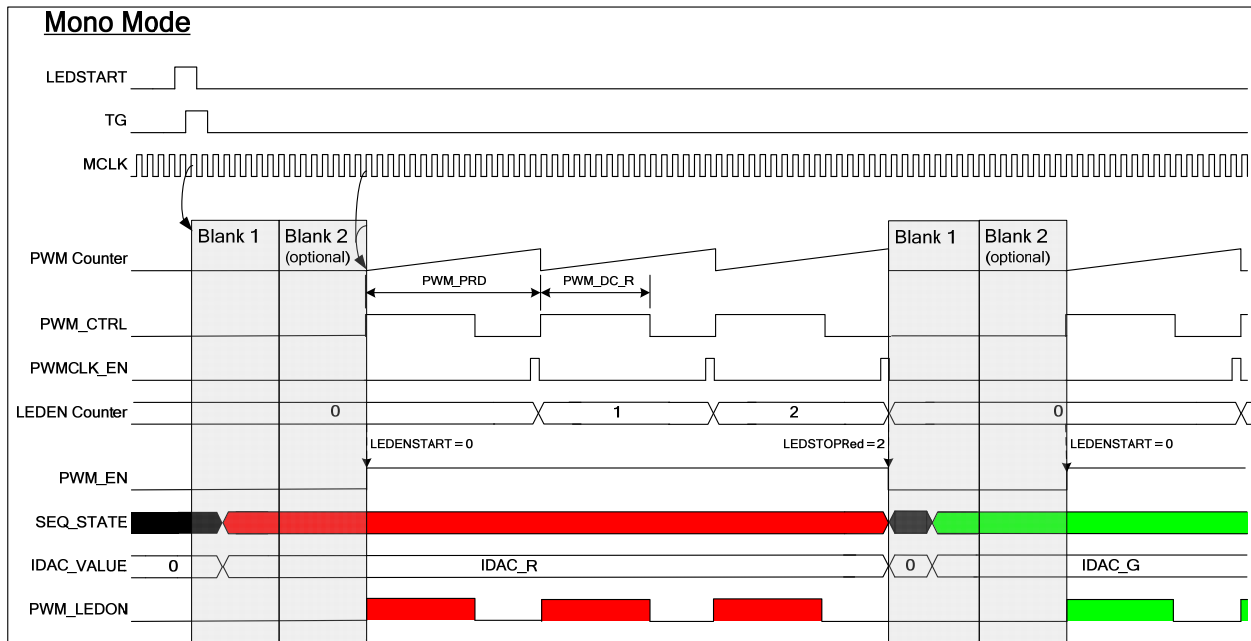

Figure 21 PWMLED Current Control Timing – Monochrome Scan with PWM Duty Cycle

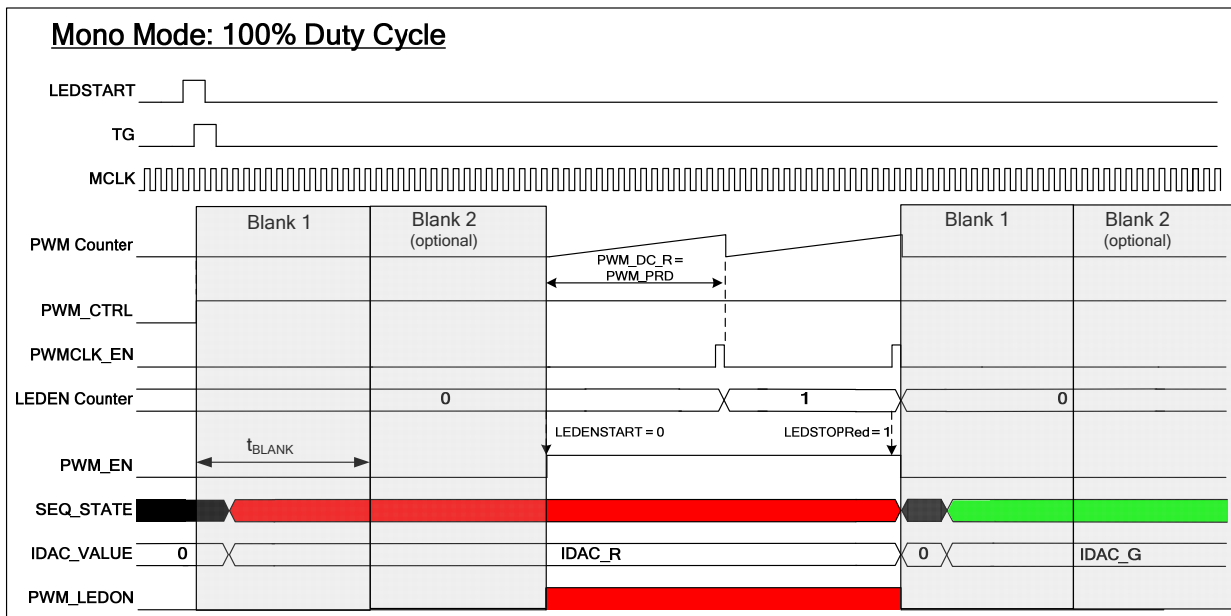

Figure 22 PWMLED Current Control Timing – Monochrome Scan with 100% PWM Duty Cycle (PWM functionality disabled)

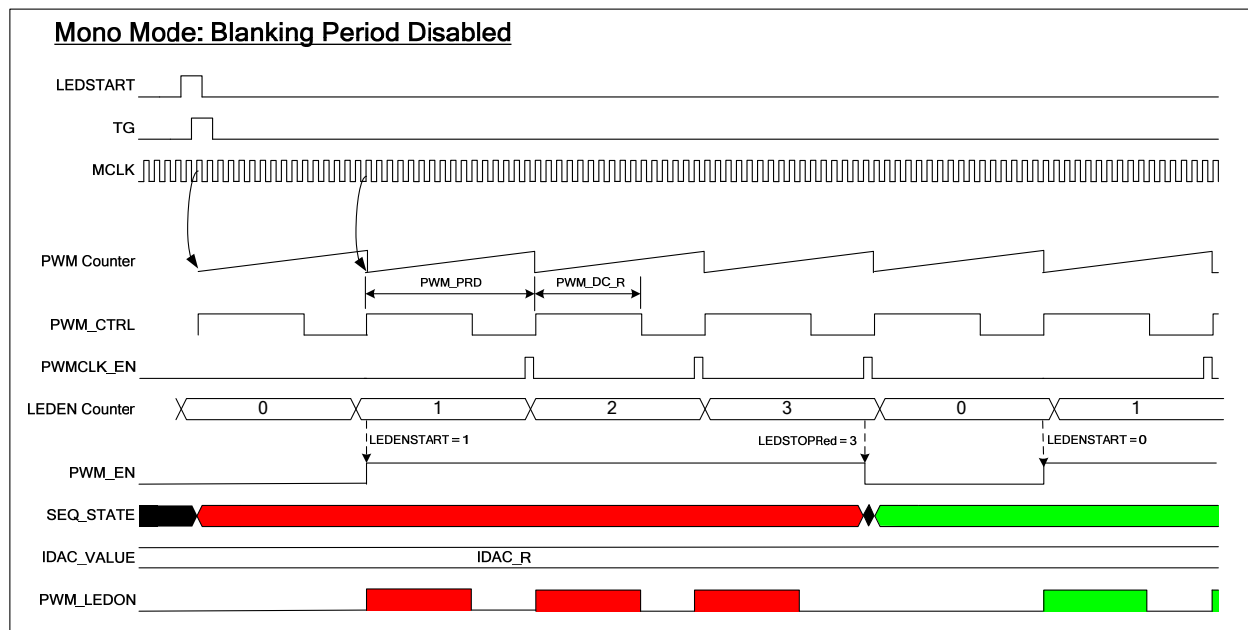

Figure 23 PWM LED Current Control Timing - Monochromatic Scan with PWM Duty Cycle and Blanking Period Disabled

CURRENT ACCURACY AND ABSOLUTE MAXIMUM CURRENT LIMIT

To protect the LED when operated near its maximum operating current range, an accurate absolute maximum current limit can be set.

An external resistor connected to the EXTRES pin must be provided to generate an accurate reference current for the LED circuit. As the current DAC is designed for low compliance voltage, a separate higher accuracy current detection circuit is provided.

At the start of every state change the Current DAC setting for that LED is measured (Red, Green or Blue). If the state machine is at RED and the current, LEDIDACR, exceeds the absolute maximum current limit, a register, LEDRFLAG will be set. If ILIMITEN is set to the appropriate mode, the current will be automatically reduced and the current retested. Should this new current be within the safe operating area the Red LED will be enabled. The LEDRFLAG register will remain set to indicate that the reduction has been implemented.

The next time the state machine enters the RED state, the current value is measured again. If the current, LEDIDACR is now an acceptable value (without a reduction) the LEDRFLAG will reset. This is the same when in the GREEN and BLUE states, where LEDIDACG and LEDIDACB are measured respectively. Note that for the initial current test of a new state, the machine always loads the Current DAC register setting, not a reduced value previously used.

Throughout the DAC loading and current limit testing, the LED is disabled and the current is steered through the power supply AVDD1. This prevents stress in the LED, by ensuring that it is not enabled until the current is within the safe operating area.

A register bit ILIMITFLAG will get set when any of the LED Flags are set. All of the Flags will be reset when applying a LED Software Reset.

For example:

The Red LED maximum current is 53mA in this example.

LEDIRNGR = 11 which gives an absolute maximum current of 68 mA.

LEDIMAX = 1 which gives a maximum limit of up to 53 mA.

ILIMITDEC = 1 which sets reduction to 25%

ILIMITEN = 01 which enables current reduction

LEDRFLAG and subsequently ILIMITFLAG will be set and LED current will be reduced to: $68 \text{ mA} * (1 - 0.25) = 51 \text{ mA}$

This is within the safe operating area of the LED to be driven.

In the case of a safe operating area test fail, the LED current will be reduced by 25% to give a maximum limit of up to 39.75 mA

Should this LED current drive be insufficient during operation it may be calibrated until a target is met. The algorithm used to control the calibration of the LED DAC current is user specific but it has access to the LED Flags, ILIMITFLAG and the LED current DAC register values.

A binary incremental or binary weighted search may be used to increase the LED DAC current to the absolute current maximum limit. An indication of how to perform a binary incremental search is mentioned below.

A SUGGESTED BINARY INCREMENTAL SEARCH IMPLEMENTED BY THE USER

When the LED maximum current is detected, the LED current can be trimmed back by either 12.5% or 25%, depending on ILIMITDEC. At 25% this will guarantee the LED current is below the LED DAC absolute maximum current limit. The LED current can then be incremented by an LSB of the LED current register. The LED current will continue to be incremented until ILIMITFLAG is again set. Figure 24 shows this process graphically.

The LSB of the current is 0.4% of the full LED current DAC full scale range. As a result the LED current DAC may trim the LED current drive to within +/-0.2% of target.

If the coarse LED current limit is 35mA to 53mA when LEDIMAX=1, this means the trip point accuracy will be:-

$$\text{Min. Limit} - ((\text{Min. Full Scale Range}/255)/2) \gg \text{Max. Limit} + ((\text{Max. Full Scale Range}/255)/2)$$

In this case LEDRNG = 11 so Min. FSR is 50 and Max FSR is 68.

LEDIMAX=1 so Min. Limit is 35 and Max. Limit is 53.

Therefore:-

$$35 - ((50/255) / 2) \gg 53 + ((68/255) / 2) \quad \text{gives} \quad 35 - (0.196/2) \gg 53 + (0.266/2)$$

$$= 34.9 \gg 53.13 \quad \text{or} \quad 44 \pm 20.75\%$$

During the binary incremental search, the LED current will continue to be incremented until ILIMITFLAG is again set. At this point it is desirable to disable the reduction of the LED current. Different options to disable the reduction of current can be achieved through the register bit ILIMITEN. Refer to Table 4 in the Blank Period Section.

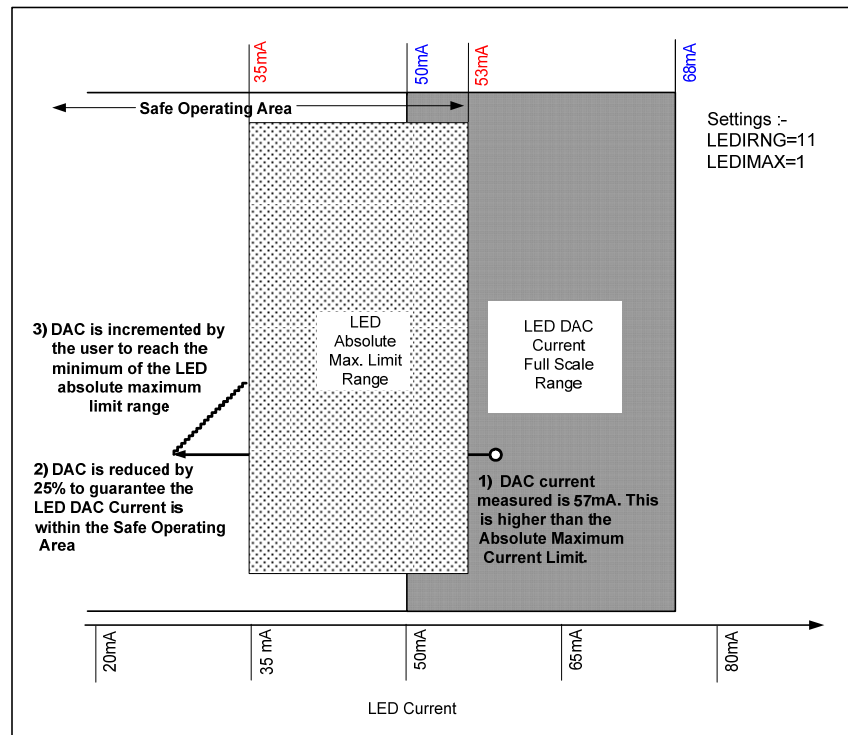

Figure 24 An Example of How LED Current Limiting Can Be Operated

LED CONTROL WORKED EXAMPLE

As an example of configuring the LED current drive control, consider the scan of a US Letter page size with the AFE configured to sample at 12 MHz MCLK and 3:1 MCLK:VSMP ratio.

The aim is to calculate LEDPWMPER for the given MCLK frequency to give a PWM frequency of typically 2.5kHz. Then the number of PWM cycles per line scan is calculated to check that there is sufficient imaging time and coarse trim range.

Assumptions

MCLK:VSMP ratio	= 3:1
MCLK frequency	= 12MHz
VSMP frequency	= 4MHz
LED Enable counter range	= 2^7 (maximum) PWM clock periods
LED PWM counter range	= 2^{12} (maximum) PWM clock periods
Colour Scan Mode	
Target blanking period	= 25uSec
Desired PWM frequency	= 2.5kHz
Colour sequence	= red, green, blue
Sensor scan width	= 9 inches
Scan resolution	= 2400 dpi

- The number of MCLK cycles per PWM period is given by:

$$\text{LEDPWMPER} = 12 \text{ MHz} / 2.5\text{kHz} = 4800.$$

This exceeds the maximum 4095 so CLKDIV must be set to '0001'.

Therefore $12\text{MHz} / 2 = 6\text{MHz}$

$$\text{Therefore LEDPWMPER} = 6\text{MHz} / 2.5\text{kHz} = 2400$$

- The number of MCLK cycles necessary for blanking period is given by:

$$(t_{\text{BLANK}} * 0.8) * \text{MCLK} = \text{INITBLANK}_{\text{dec.}}$$

$$(25\mu\text{Sec} * 0.8) * 12\text{MHz} = 240$$

The binary equivalent of $\text{INITBLANK}_{\text{dec}}$ should be calculated and, making sure the last 3 LSBs are zero, should be set in the register.

$240 = 0\ 1111\ 0000\text{bin}$. Therefore the 6 MSBs to be set to the register INITBLANK are :- 011110bin

By default INITBLANK is set to zero which sets the initial blank period to equal the PWM period/0.8

- The number of MCLK cycles per line scan is given by:

$$\text{MCLK cycles per line scan} = 9\text{inch} * 2400\text{dpi} * 3 = 64800$$

- The number of MCLK cycles available for imaging is given by:

$$\text{MCLK cycles per line scan} - \text{MCLK cycles per line scan} = 64800 - 240 = 64560$$

- The Number of PWM cycles per line scan is given by:

$$\text{MCLK cycles per PWM period LEDPWMPER} = 2400$$

$$\text{Number of PWM cycles per line scan} = 64560 / 2400 = 26.9$$

The nearest integral number of PWM cycles per line scan then 26.

The illumination period should be checked. Assuming 26 PWM cycles per line, with the first PWM cycle reserved for the current DAC setup and transition, and an 80% duty cycle

$$\text{Period of illumination} = 26 * 0.8 / 2.5\text{kHz} = 8.32 \text{ msec}$$

$$\text{Period of illumination coarse trim LSB} = 1 / 2.5\text{kHz} = 400 \text{ usec}$$

$$\text{Period of illumination fine trim LSB} = 1 / 6\text{MHz} = 166.66 \text{ nsec}$$

If the period of illumination per line scan is too short, the imaging period is limiting the scan period. The period between TG pulses should be increased and step 2 should be repeated to calculate the number of MCLK cycles per line scan.

Set values for LEDPWMDCR / G / B as appropriate.

Using the number of PWM cycles per line scan for reference, set values for LEDENSTART and LEDENSTOPR / G / B as appropriate.

Set values for LEDIDACR / G / B as appropriate.

A red, green, blue, red, green, blue colour transition is required, so set STATE0 = 00 for red, STATE1 = 01 for green and STATE2 = 10 for blue. Set STATERST = 10

CONTROL INTERFACE

The internal control registers are programmable via the serial digital control interface. The register contents can be read back via the serial interface on pin OP[3]/SDO.

It is recommended that a software reset is carried out after the power-up sequence, before writing to any other register. This ensures that all registers are set to their default values (as shown in Table 8).

SERIAL INTERFACE: REGISTER WRITE

Figure 25 shows register writing in serial mode. Three pins, SCK, SDI and SEN are used. A six-bit address (a5, 0, a3, a2, a1, a0) is clocked in through SDI, MSB first, followed by an eight-bit data word (b7, b6, b5, b4, b3, b2, b1, b0), also MSB first. Each bit is latched on the rising edge of SCK. When the data has been shifted into the device, a pulse is applied to SEN to transfer the data to the appropriate internal register. Note all valid registers have address bit a4 equal to 0 in write mode.

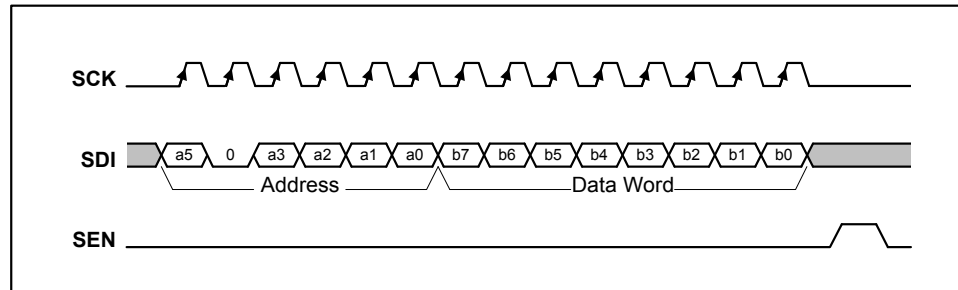

Figure 25 Serial Interface Register Write

A software reset is carried out by writing to Address “000100” with any value of data, (i.e. Data Word = XXXXXXXX).

SERIAL INTERFACE: REGISTER READ-BACK

Figure 26 shows register read-back in serial mode. Read-back is initiated by writing to the serial bus as described above but with address bit a4 set to 1, followed by an 8-bit dummy data word. Writing address (a5, 1, a3, a2, a1, a0) will cause the contents (d7, d6, d5, d4, d3, d2, d1, d0) of corresponding register (a5, 0, a3, a2, a1, a0) to be output MSB first on pin SDO (on the falling edge of SCK). Note that pin SDO is shared with an output pin, OP[3], so no data can be read when reading from a register. The next word may be read in to SDI while the previous word is still being output on SDO.

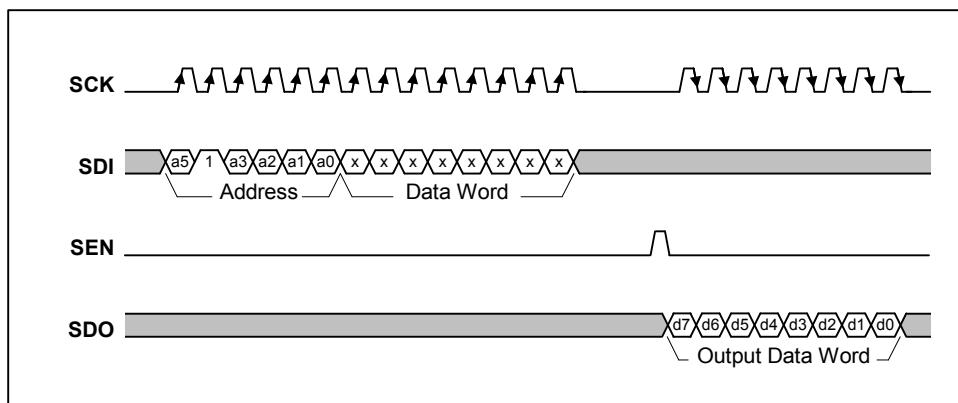

Figure 26 Serial Interface Register Read-back

TIMING REQUIREMENTS

To use this device a master clock (MCLK) of up to 24MHz and a per-pixel synchronisation clock (VSMP) of up to 12MHz is required. These clocks drive a timing control block, which produces internal signals to control the sampling of the video signal. MCLK to VSMP ratios and maximum sample rates for the various modes are shown in Table 6.

PROGRAMMABLE VSMP DETECT CIRCUIT

The VSMP input is used to determine the sampling point and frequency of the WM8255. Under normal operation a pulse of 1 MCLK period should be applied to VSMP at the desired sampling frequency (as shown in the Operating Mode Timing Diagrams) and the input sample will be taken on the first rising MCLK edge after VSMP has gone low. However, in certain applications such a signal may not be readily available. The programmable VSMP detect circuit in the WM8255 allows the sampling frequency to be derived from any signal of the correct frequency, such as a CCD shift register clock, when applied to the VSMP pin.

When enabled, by setting the VSMPDET control bit, the circuit detects either a rising or falling edge (determined by POSNNEG control bit) on the VSMP input pin and generates an internal VSMP pulse. This pulse can optionally be delayed by a number of MCLK periods, specified by the VDEL[2:0] bits. Figure 27 shows the internal VSMP pulses that can be generated by this circuit for a typical clock input signal. The internal VSMP pulse is then applied to the timing control block in place of the normal VSMP pulse provided from the input pin. The sampling point then occurs on the first rising MCLK edge after this internal VSMP pulse, as shown in the Operating Mode Timing Diagrams.

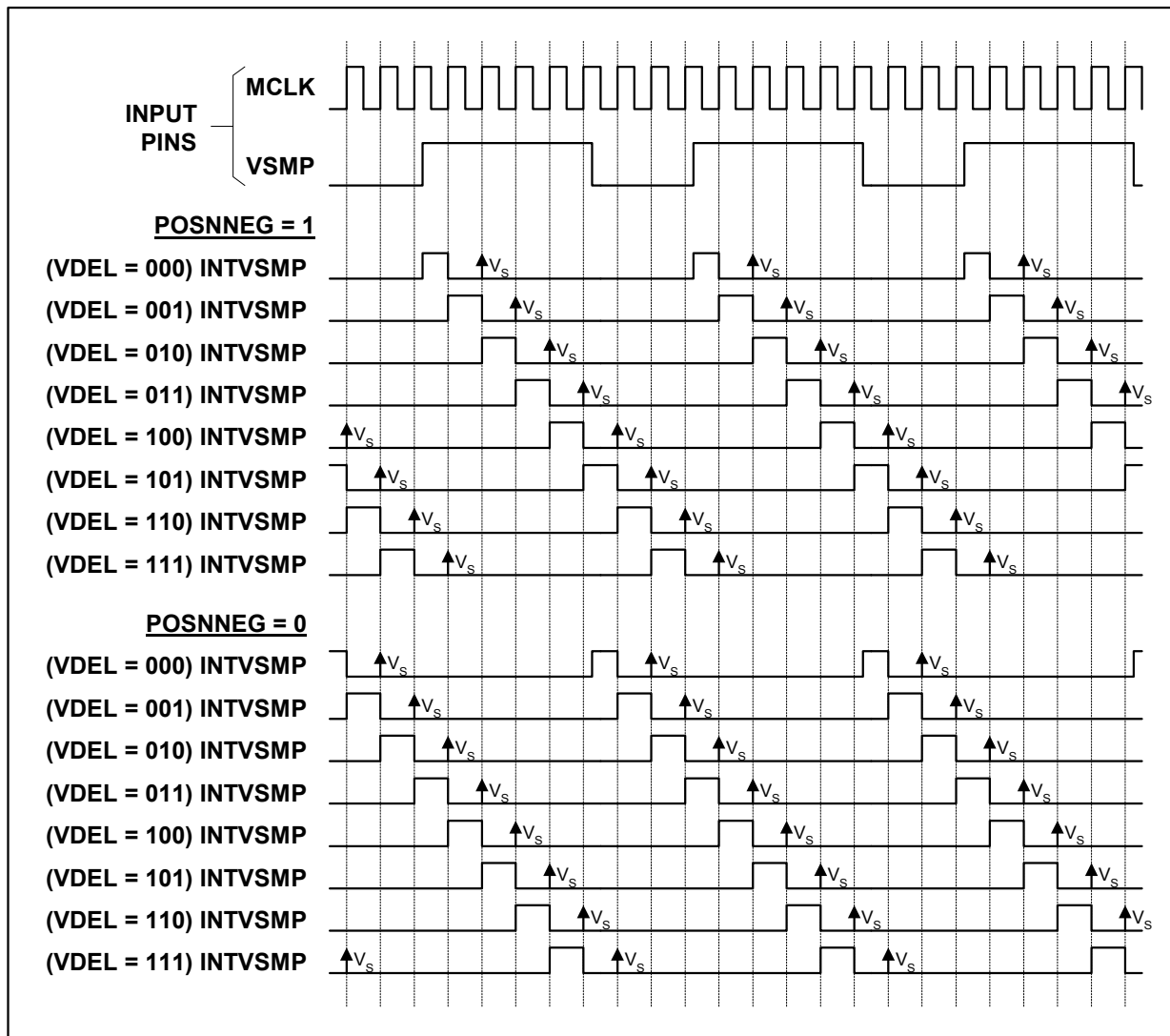

Figure 27 Internal VSMP Pulses Generated by Programmable VSMP Detect Circuit

REFERENCES

The ADC reference voltages are derived from an internal band-gap reference, and buffered to pins VRT and VRB, where they must be decoupled to ground. The output buffer from the RLCDAC also requires decoupling at pin VRVC/VBIAS when this is configured as an output.

POWER SUPPLY

The WM8255 operates from either a 5.75V (AVDD1) supply or a 3.3V (AVDD2).

POWER MANAGEMENT

The WM8255 has a power management system to detect the presence and correct level of the power supplies AVDD1, AVDD2 and DVDD.

With reference to Figure 28, the WM8255 is partitioned into three power domains, a digital domain powered by DVDD, LED current drive domain powered by AVDD1 and AFE domain powered by AVDD2. In the digital domain, until DVDD has reached the correct level, a Power On Reset (POR) shall disable the WM8255. The LDO voltage regulator and AFE voltage references shall be enabled and allowed to power up as AVDD1 is applied when the POR released. With AVDD1, AVDD2 and AFE voltage references at the correct level a system enable is set and WM8255 shall power up in a controlled manner.

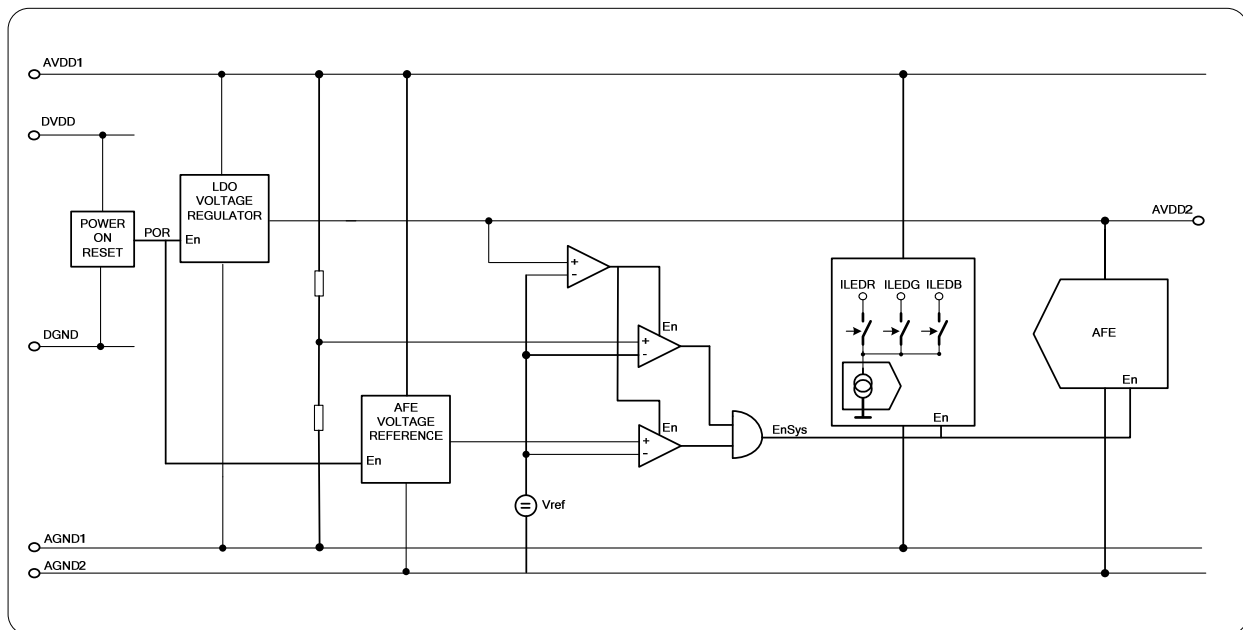

Figure 28 Power Management System

Power management for the device is performed via the Control Interface. The device can be powered on or off completely by setting the EN bit low.

All the internal registers maintain their previously programmed value in power down mode and the Control Interface inputs remain active.

POWER ON SEQUENCE

In order to guarantee correct operation, the digital supply (DVDD) and analogue supply (AVDD1) should be applied as specified in Figure 29 and Table 5.

If it is not possible to apply the recommended power up sequence, the user must wait until both DVDD and AVDD1 have risen fully, then disable and enable the WM8255 by software write to EN (R0, b0). It is then possible to apply further register writes and operate the WM8255 correctly.

When powering down the WM8255, no specific power down sequence is required.

REDUCED POWER

With DVDD applied, AVDD1 may be powered down with no loss to digital configuration data. This will reduce the power consumption of the device whilst still keeping register settings and configurations.

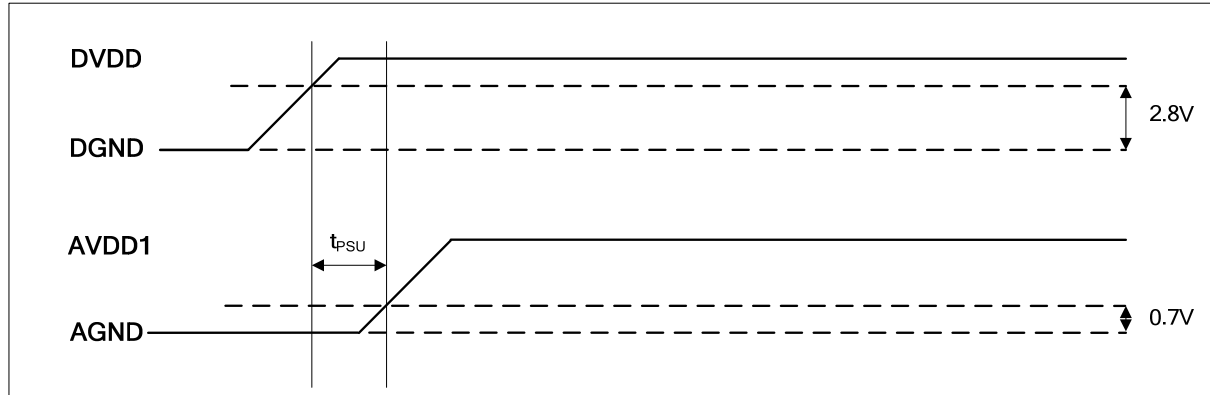

Figure 29 Power On Sequence

Test Conditions

AVDD1 = 5.75V, DVDD = 3.3V, AGND = DGND = AVDD2 = 0V, $T_A = 25^\circ\text{C}$, MCLK = 24MHz unless otherwise stated.

PARAMETER	SYMBOL	TEST CONDITIONS	MIN	TYP	MAX	UNITS
DVDD set up time to AVDD1 rising edge	t_{PSU}		100			μs

Table 5 Power On Timing

OPERATING MODES

Table 6 summarises the most commonly used modes, the clock waveforms required and the register contents required for CDS and non-CDS operation.

MODE	DESCRIPTION	CDS AVAILABLE	MAX SAMPLE RATE	TIMING REQUIREMENTS	REGISTER CONTENTS WITH CDS	REGISTER CONTENTS WITHOUT CDS
1	Monochrome/ Colour Line-by-Line	Yes	6 MSPS	MCLK max = 24MHz MCLK:VSMP ratio is $2n:1$ $n \geq 2$	SetReg1: 0F(hex)	SetReg1: 0D(hex)
2	Fast Monochrome/ Colour Line-by-Line	Yes	8 MSPS	MCLK max = 24MHz MCLK:VSMP ratio is 3:1	Identical to Mode 1 plus SetReg3: bits 5:4 must be set to 0(hex)	Identical to Mode 1
3	Maximum speed Monochrome/ Colour Line-by-Line	No	12 MSPS	MCLK max = 24MHz MCLK:VSMP ratio is 2:1	CDS not possible	SetReg1: 4D(hex)

Table 6 WM8255 Operating Modes

***Note:** Maximum sample rate depends on the MCLK to VSMP ratio. A higher ratio will mean a lower maximum sample rate for a specified MCLK speed.

OPERATING MODE TIMING DIAGRAMS

The following diagrams show 4-bit multiplexed output data and MCLK, VSMP and input video requirements for operation of the most commonly used modes as shown in Table 6. The diagrams are identical for both CDS and non-CDS operation.

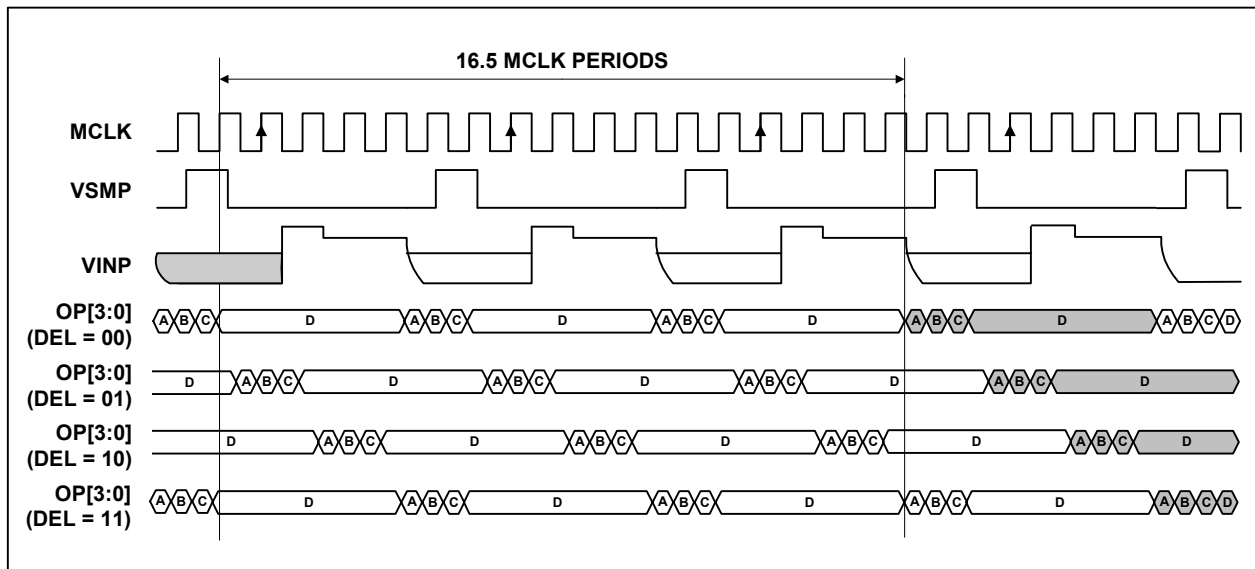

Figure 30 Mode 1 Operation

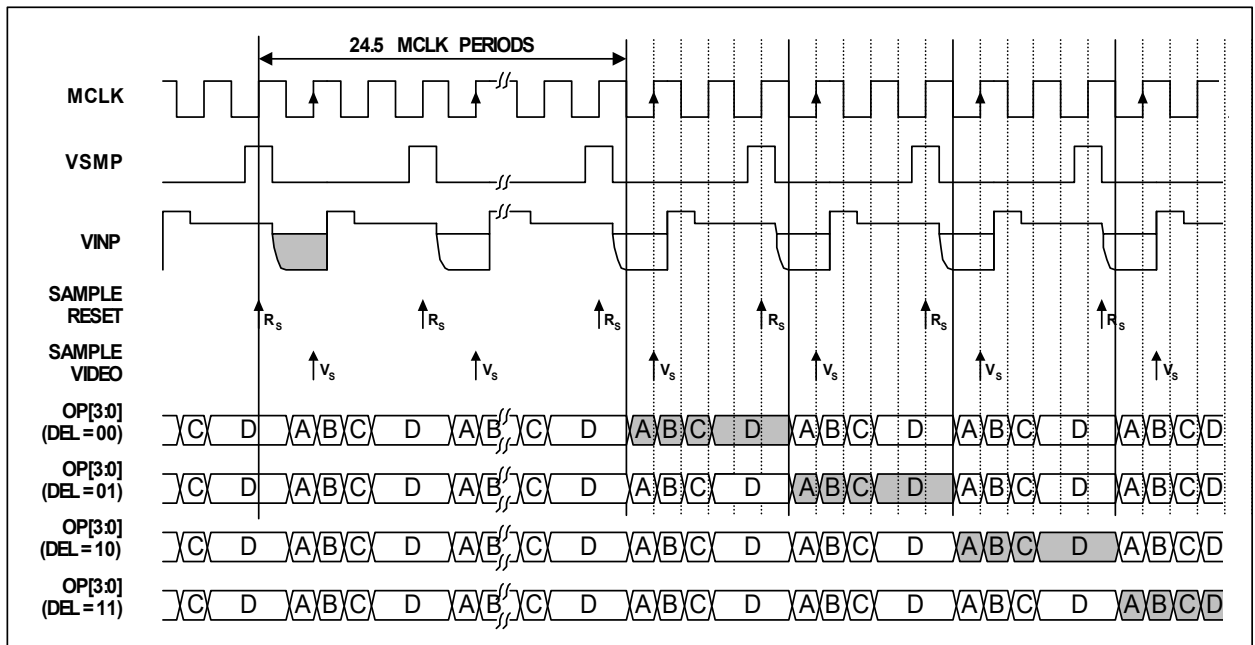

Figure 31 Mode 2 Operation

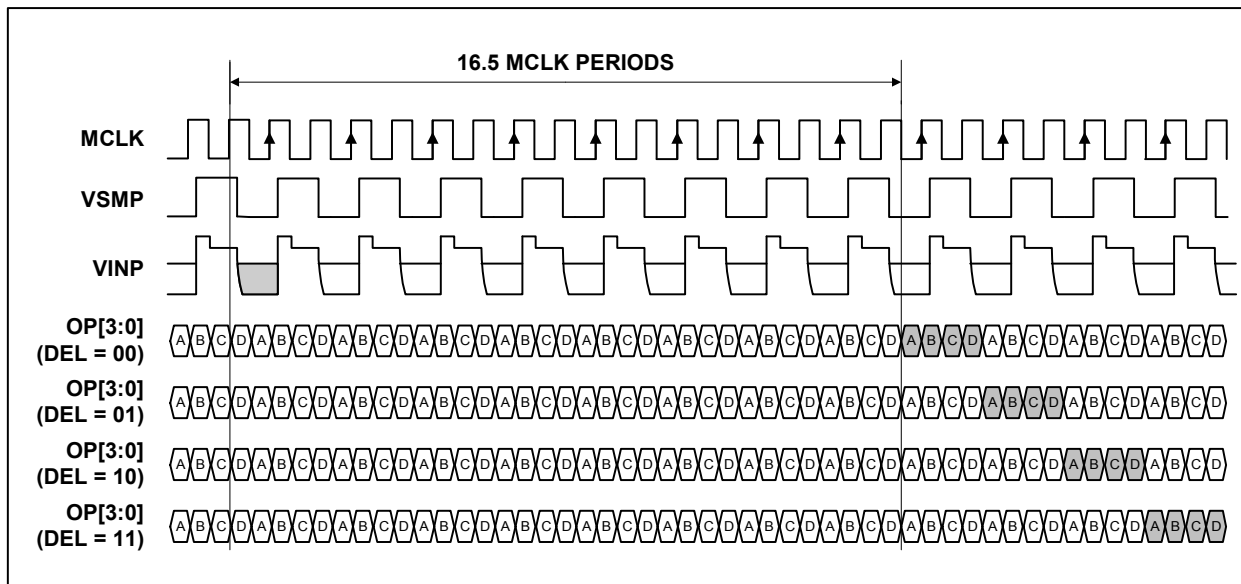

Figure 32 Mode 3 Operation

DEVICE REVISION CODES

To read the device revision code the test registers must be accessed. Table 7 defines the method:

DEVICE REVISION CODE		
Address	Data	Comment
0x01	0xA3	This will put the part into test configuration mode. Any address will now point to the extended page reconfiguration register
0x27	Read	Read all eight bits of this register. Bit[7:1] contain the revision code information, Bit[0] should be ignored
0x01	0x23	This will take the part back into normal operating mode.

Table 7 Revision Code

Note: For Rev C devices it will read '01'

DEVICE CONFIGURATION

REGISTER MAP

The following table describes the location of each control bit used to determine the operation of the WM8255. The register map is programmed by writing the required codes to the appropriate addresses via the serial interface.

Address <a5:a0>	Description	Def (hex)	RW	BIT							
				b7	b6	b5	b4	b3	b2	b1	b0
000001	Setup Reg 1	03	RW	TREG_OPEN	MODE3	PGAFS[1]	PGAFS[0]	VSMDET	0	CDS	EN
000010	Setup Reg 2	00	RW	DEL[1]	DEL[0]	0	RLCINT	VRLCEXT	INVOP	2BITOP	POSNEG
000011	Setup Reg 3	13	RW	INTM[1]	INTM[0]	CDSREF [1]	CDSREF [0]	RLCV[3]	RLCV[2]	RLCV[1]	RLCV[0]
000100	Software Reset	00	W								
000101	Setup Reg 4	00	RW	0	LEDIMAX	0	0	0	VDEL[2]	VDEL[1]	VDEL[0]
000110	Setup Reg 5	20	RW	LEDIDACR [7]	LEDIDACR [6]	LEDIDACR [5]	LEDIDACR [4]	LEDIDACR [3]	LEDIDACR [2]	LEDIDACR [1]	LEDIDACR [0]
000111	Setup Reg 6	20	RW	LEDIDACG [7]	LEDIDACG [6]	LEDIDACG [5]	LEDIDACG [4]	LEDIDACG [3]	LEDIDACG [2]	LEDIDACG [1]	LEDIDACG [0]
001000	Setup Reg 7	20	RW	LEDIDACB [7]	LEDIDACB [6]	LEDIDACB [5]	LEDIDACB [4]	LEDIDACB [3]	LEDIDACB [2]	LEDIDACB [1]	LEDIDACB [0]
001001	Setup Reg 8	C0	RW	STATE_ RST[1]	STATE_ RST[0]	0	LEDIRNGG [1]	LEDIRNGG [0]	0	LEDIRNGR [1]	LEDIRNGR [0]
001010	Setup Reg 9	00	RW	ILIMITEN [1]	ILIMITEN[0]	MONOMODE	MONOTG	REQLEDST	0	LEDIRNGB [1]	LEDIRNGB [0]
001011	Setup Reg 10	E4	RW	STATE3 [1]	STATE3 [0]	STATE2 [1]	STATE2 [0]	STATE1 [1]	STATE1 [0]	STATE0 [1]	STATE0 [0]
001100	Setup Reg 11	00	RW	LEDPWM PER[7]	LEDPWM PER[6]	LEDPWM PER[5]	LEDPWM PER[4]	LEDPWM PER[3]	LEDPWM PER[2]	LEDPWM PER[1]	LEDPWM PER[0]
001101	Setup Reg 12	00	RW	CLKDIV[3]	CLKDIV[2]	CLKDIV[1]	CLKDIV[0]	LEDPWM PER[11]	LEDPWM PER[10]	LEDPWM PER[9]	LEDPWM PER[8]
001110	Setup Reg 13	00	RW	LEDPWM DCR[7]	LEDPWM DCR[6]	LEDPWM DCR[5]	LEDPWM DCR[4]	LEDPWM DCR[3]	LEDPWM DCR[2]	LEDPWM DCR[1]	LEDPWM DCR[0]
001111	Setup Reg 14	00	RW	LEDPWM DCG[7]	LEDPWM DCG[6]	LEDPWM DCG[5]	LEDPWM DCG[4]	LEDPWM DCG[3]	LEDPWM DCG[2]	LEDPWM DCG[1]	LEDPWM DCG[0]
100000	DAC Value (Red)	80	RW	DACR[7]	DACR[6]	DACR[5]	DACR[4]	DACR[3]	DACR[2]	DACR[1]	DACR[0]
100001	DAC Value (Green)	80	RW	DACG[7]	DACG[6]	DACG[5]	DACG[4]	DACG[3]	DACG[2]	DACG[1]	DACG[0]
100010	DAC Value (Blue)	80	RW	DACB[7]	DACB[6]	DACB[5]	DACB[4]	DACB[3]	DACB[2]	DACB[1]	DACB[0]
100011	DAC Value (RGB)	80	W	DAC[7]	DAC[6]	DAC[5]	DAC[4]	DAC[3]	DAC[2]	DAC[1]	DAC[0]
100100	Setup Reg 15	00	RW	LEDPWM DCB[7]	LEDPWM DCB[6]	LEDPWM DCB[5]	LEDPWM DCB[4]	LEDPWM DCB[3]	LEDPWM DCB[2]	LEDPWM DCB[1]	LEDPWM DCB[0]
100101	Setup Reg 16	11	RW	LEDPWM DCG[11]	LEDPWM DCG[10]	LEDPWM DCG[9]	LEDPWM DCG[8]	LEDPWM DCR[11]	LEDPWM DCR[10]	LEDPWM DCR[9]	LEDPWM DCR[8]
100110	Setup Reg 17	01	RW	LEDSTART [3]	LEDSTART [2]	LEDSTART [1]	LEDSTART [0]	LEDPWM DCB[11]	LEDPWM DCB[10]	LEDPWM DCB[9]	LEDPWM DCB[8]
100111	Setup Reg 18	10	RW	LEDSTART [4]	LEDSTOPR [6]	LEDSTOPR [5]	LEDSTOPR [4]	LEDSTOPR [3]	LEDSTOPR [2]	LEDSTOPR [1]	LEDSTOPR [0]
101000	PGA Gain (Red)	00	RW	PGAR[7]	PGAR[6]	PGAR[5]	PGAR[4]	PGAR[3]	PGAR[2]	PGAR[1]	PGAR[0]
101001	PGA Gain (Green)	00	RW	PGAG[7]	PGAG[6]	PGAG[5]	PGAG[4]	PGAG[3]	PGAG[2]	PGAG[1]	PGAG[0]
101010	PGA Gain (Blue)	00	RW	PGAB[7]	PGAB[6]	PGAB[5]	PGAB[4]	PGAB[3]	PGAB[2]	PGAB[1]	PGAB[0]

Address <a5:a0>	Description	Def (hex)	RW	BIT							
				b7	b6	b5	b4	b3	b2	b1	b0
101011	PGA Gain (RGB)	00	W	PGA[7]	PGA[6]	PGA[5]	PGA[4]	PGA[3]	PGA[2]	PGA[1]	PGA[0]
101100	Setup Reg 19	10	RW	LEDSTART [5]	LEDSTOPG [6]	LEDSTOPG [5]	LEDSTOPG [4]	LEDSTOPG [3]	LEDSTOPG [2]	LEDSTOPG [1]	LEDSTOPG [0]
101101	Setup Reg 20	10	RW	LEDSTART [6]	LEDSTOPB [6]	LEDSTOPB [5]	LEDSTOPB [4]	LEDSTOPB [3]	LEDSTOPB [2]	LEDSTOPB [1]	LEDSTOPB [0]
101110	Setup Reg 21	00	RW	ILIMITFLAG	ILIMITDEC	INITBLANK [8]	INITBLANK [7]	INITBLANK [6]	INITBLANK [5]	INITBLANK [4]	INITBLANK [3]
101111	LED Software Reset	00	W								
	LED RGB Flags	00	R						LEDRFLAG	LEDGFLAG	LEDBFLAG

Table 8 Register Map

EXTENDED PAGE REGISTERS

Address <a5:a0>	Description	Def (hex)	RW	BIT							
				b7	b6	b5	b4	b3	b2	b1	b0
100100	LED Control			0	0	LED_TEST CTRL[3]	LED_TEST CTRL[2]	LED_TEST CTRL[1]	LED_TEST CTRL[0]	0	0
100111	Revision Number			REV_NUM [6]	REV_NUM [5]	REV_NUM [4]	REV_NUM [3]	REV_NUM [2]	REV_NUM [1]	REV_NUM [0]	X

Table 9 Extended Page Registers

Note: To access the Extended Page Registers the TREG_OPEN bit must be set to '1' in Setup Reg 1. This bit must then be set to '0' once access is complete. Please refer to Pages 23 and 38 for details on when to access these registers.

REGISTER MAP DESCRIPTION

The following table describes the function of each of the control bits shown in Table 8.

REGISTER	BIT NO	BIT NAME(S)	DEFAULT	DESCRIPTION
Setup Register 1	0	EN	1	0 = complete power down, 1 = fully active.
	1	CDS	1	Select correlated double sampling mode: 0 = single ended mode, 1 = CDS mode.
	2	Reserved	0	Must be set to zero
	3	VSMPDET	0	0 = Normal operation, signal on VSMP input pin is applied directly to Timing Control block. 1 = Programmable VSMP detect circuit is enabled. An internal synchronization pulse is generated from signal applied to VSMP input pin and is applied to Timing Control block.
	5:4	PGAFS[1:0]	00	Offsets PGA output to optimize the ADC range for different polarity sensor output signals. Zero differential PGA input signal gives: 00 = Zero output 01 = Zero output 10 = Full-scale positive output (use for bipolar video) 11 = Full-scale negative output (use for positive going video)
	6	MODE3	0	Required when operating in MODE3: 0 = other modes, 1 = MODE3.
	7	TREG_OPEN	0	Enables the extended page register access

REGISTER	BIT NO	BIT NAME(S)	DEFAULT	DESCRIPTION
Setup Register 2	0	POSNEG	0	When VSMPDET = 0 this bit has no effect. When VSMPDET = 1 this bit controls whether positive or negative edges are detected: 0 = Negative edge on VSMP pin is detected and used to generate internal timing pulse. 1 = Positive edge on VSMP pin is detected and used to generate internal timing pulse. See Figure 27 for further details.
	1	2BITOP	0	Changes the digital output from 4 bit muxed to 2 bit muxed output.
	2	INVOP	0	Digitally inverts the polarity of output data. 0 = negative going video gives negative going output, 1 = negative-going video gives positive going output data.
	3	VRLCEXT	0	When set powers down the RLCDAC, changing its output to Hi-Z, allowing VRLC/VBIAS to be externally driven.
	4	RLCINT	0	This bit is used to determine whether Reset Level Clamping is enabled. 0 = RLC disabled, 1 = RLC enabled.
	5	Reserved	0	Must be set to zero.
	7:6	DEL[1:0]	00	Sets the output latency in ADC clock periods. 1 ADC clock period = 2 MCLK periods except in Mode 2 where 1 ADC clock period = 3 MCLK periods. 00 = Minimum latency 10 = Delay by two ADC clock periods 01 = Delay by one ADC clock 11 = Delay by three ADC clock periods period
Setup Register 3	3:0	RLCV[3:0]	0011	Controls RLCDAC driving VRLC pin to define single ended signal reference voltage or Reset Level Clamp voltage. See Electrical Characteristics section for ranges.
	5:4	CDSREF[1:0]	01	CDS mode reset timing adjust. 00 = Advance 1 MCLK period 10 = Retard 1 MCLK period 01 = Normal 11 = Retard 2 MCLK periods
	7:6	INTM[1:0]	00	Colour selection bits used in internal modes. 00 = Red, 01 = Green, 10 = Blue and 11 = Reserved. See Table 1 for details.
Software Reset				Any write to Software Reset causes all cells (including LED) to be reset. It is recommended that a software reset be performed after a power-up before any other register writes.
Setup Register 4	2:0	VDEL[2:0]	000	When VSMPDET = 0 these bits have no effect. When VSMPDET = 1 these bits set a programmable delay from the detected edge of the signal applied to the VSMP pin. The internally generated pulse is delayed by VDEL MCLK periods from the detected edge. See Figure 27, Internal VSMP Pulses Generated for details.
	5:3	Reserved	000	Must be set to zero
	6	LEDIMAX	0	Sets the maximum current limit to one of two ranges (see electrical characteristics section).
	7	Reserved	0	Must be set to zero
Setup Register 5	7:0	LEDIDACR [7:0]	00100000	Fine LED current during imaging for Red LED
Setup Register 6	7:0	LEDIDACG [7:0]	00100000	Fine LED current during imaging for Green LED
Setup Register 7	7:0	LEDIDACB [7:0]	00100000	Fine LED current during imaging for Blue LED
Setup Register 8	1:0	LEDIRNGR [1:0]	00	Coarse LED current range during imaging for Red LED
	2	Reserved	0	Must be set to zero

REGISTER	BIT NO	BIT NAME(S)	DEFAULT	DESCRIPTION
	4:3	LEDIRNGG [1:0]	00	Coarse LED current range during imaging for Green LED
	5	Reserved	0	Must be set to zero
	7:6	STATERST [1:0]	11	State reset. Sets the number of states to be used. 00 = State_0 only 01 = State_0 to State_1 10 = State_0 to State_2 11 = State_0 to State_3
Setup Register 9	1:0	LEDIRNGB [1:0]	00	Coarse LED current range during imaging for Blue LED
	2	Reserved	0	Must be set to zero
	3	REQLEDST	0	If LEDSTART is to be used this register must be set high
	4	MONOTG	0	When MONOMODE=0 this register has no effect. When set high allows the TG pin to restart the colour sequence when in mono mode.
	5	MONOMODE	0	When set, puts the LED control in to monochrome (composite mode)
	7:6	ILIMITEN[1:0]	00	Specifies the mode of operation of current limiting of the LED DAC. See Table 4 for details.
Setup Register 10	1:0	STATE0[1:0]	00	Sets the State 0 colour setting. Red = 00 Green = 01 Blue = 10 Off = 11
	3:2	STATE1[1:0]	01	Sets the State 1 colour setting. Red = 00 Green = 01 Blue = 10 Off = 11
	5:4	STATE2[1:0]	10	Sets the State 2 colour setting. Red = 00 Green = 01 Blue = 10 Off = 11
	7:6	STATE3[1:0]	11	Sets the State 3 colour setting. Red = 00 Green = 01 Blue = 10 Off = 11
Setup Register 11	7:0	LEDPWMPER [7:0] (LSBs)	00000000	Sets the LSBs of the maximum value for the LED PWM period. [7:0]
Setup Register 12	3:0	LEDPWMPER [11:8] (MSBs)	0000	Sets the MSBs of the maximum value for the LED PWM period. [11:8]
	7:4	CLKDIV [3:0]	0000	Sets the division of MCLK applied to the PWM counter.
Setup Register 13	7:0	LEDPWMDCR [7:0] (LSBs)	00000000	Sets the LSBs of the LED PWM Duty Cycle for the RED LED. [7:0]
Setup Register 14	7:0	LEDPWMDCG [7:0] (LSBs)	00000000	Sets the LSBs of the LED PWM Duty Cycle for the GREEN LED. [7:0]
Offset DAC (Red)	7:0	DACR[7:0]	10000000	Red channel offset DAC value. Used under control of the INTM[1:0] control bits.
Offset DAC (Green)	7:0	DACG[7:0]	10000000	Green channel offset DAC value. Used under control of the INTM[1:0] control bits.
Offset DAC (Blue)	7:0	DACB[7:0]	10000000	Blue channel offset DAC value. Used under control of the INTM[1:0] control bits.
Offset DAC (RGB)	7:0	DAC[7:0]		A write to this register location causes the red, green and blue offset DAC registers to be overwritten by the new value.
Setup Register 15	7:0	LEDPWMDCB [7:0] (LSBs)	00000000	Sets the LSBs of the LED PWM Duty Cycle for the BLUE LED. [7:0]
Setup Register 16	3:0	LEDPWMDCR [11:8] (MSBs)	0001	Sets the MSBs of the LED PWM Duty Cycle for the RED LED. [11:8] The LEDPWMDCR must not be set to zero (MSB and LSB both zero)
	7:4	LEDPWMDCG [11:8] (MSBs)	0001	Sets the MSBs of the LED PWM Duty Cycle for the GREEN LED. [11:8] The LEDPWMDCG must not be set to zero (MSB and LSB both zero)
Set up Register 17	3:0	LEDPWMDCB [11:8] (MSBs)	0001	Sets the MSBs of the LED PWM Duty Cycle for the BLUE LED. [11:8] The LEDPWMDCB must not be set to zero (MSB and LSB both zero)
	7:4	LEDSTART [3:0]	0000	Sets the LSBs of the 7 bit LEDSTART time. [3:0]

REGISTER	BIT NO	BIT NAME(S)	DEFAULT	DESCRIPTION
Setup Register 18	6:0	LEDSTOPR [6:0]	0010000	Sets the LED stop time for the RED LED.
	7	LEDSTART [4]	0	Sets the next significant bit of the 7 bit LEDSTART time. [4]
PGA gain (Red)	7:0	PGAR[7:0]	0	Determines the gain of the red channel PGA according to the equation: Red channel PGA gain = $[0.78+(PGAR[7:0]*7.57)/255]$. Used under control of the INTM[1:0] control bits.
PGA gain (Green)	7:0	PGAG[7:0]	0	Determines the gain of the green channel PGA according to the equation: Green channel PGA gain = $[0.78+(PGAG[7:0]*7.57)/255]$. Used under control of the INTM[1:0] control bits.
PGA gain (Blue)	7:0	PGAB[7:0]	0	Determines the gain of the blue channel PGA according to the equation: Blue channel PGA gain = $[0.78+(PGAB[7:0]*7.57)/255]$. Used under control of the INTM[1:0] control bits.
PGA gain (RGB)	7:0	PGA[7:0]		A write to this register location causes the red, green and blue PGA gain registers to be overwritten by the new value
Setup Register 19	6:0	LEDSTOPG [6:0]	0010000	Sets the LED stop time for the GREEN LED.
	7	LEDSTART [5]	0	Sets the next significant bit of the 7 bit LEDSTART time. [5]
Setup Register 20	6:0	LEDSTOPB [6:0]	0010000	Sets the LED stop time for the BLUE LED.
	7	LEDSTART [6]	0	Sets the MSB of the 7 bit LEDSTART time. [6]
Setup Register 21	5:0	INITBLANK [8:3]	000000	Sets the 6 MSBs of the 9 bit register to adjust the initial blank period following a sequence transition. The 3 LSBs are fixed to zero. Must be set so the initial blank period is 25 μ s. See Initial Blank Period on page 25 for details.
	6	ILIMITDEC	0	When ILIMITEN = 0 this register has no effect. When the maximum LED current limit is exceeded and the ILIMITFLAG is set, the current is reduced to a safe level to protect the LED. 0 = 12.5% reduction in current 1 = 25% reduction in current
	7	ILIMITFLAG	0	When ILIMITEN=00 this read register will not be active. Read only register. Set high by the device when the current limit has been exceeded.
LED Reset				Resets all LED timing control to its reset state at register write
LED RGB FLAGS	0	LEDBFLAG	0	Set high by the device when the current limit has been exceeded for the Blue LED. May be read.
	1	LEDGFLAG	0	Set high by the device when the current limit has been exceeded for the Green LED. May be read.
	2	LEDRFLAG	0	Set high by the device when the current limit has been exceeded for the Red LED. May be read.

Table 10 Register Control Bits

EXTENDED PAGE REGISTER MAP DESCRIPTION

REGISTER	BIT NO	BIT NAME(S)	DEFAULT	DESCRIPTION
LED Control	1:0	Reserved	0	Must be set to zero
	5:2	LED_TESTCTRL [3:0]	0000	General LED test modes: LED_TESTCTRL[1:0] = Mode override. The IDAC can be forced into one of three modes: 01 = IDAC_LOAD: IDAC is loaded with new current value (based on the current state), and CHANGE_SETUP & IDAC_DISABLE are high. 10 = IDAC_CHECK: RGB switch is enabled (based on current state) and IDAC_CALIBRATE is set high. Current setting will not change unless test load is enabled. 11 = IDAC_ON: IDAC is fully out of reset. PWM_LEDON will still be driven by the counters unless the test override is used. Current setting will not change unless test load is enabled. LED_TESTCTRL[2] = Test update. The current setting is continuously reloaded (from Red register when machine in reset). LED_TESTCTRL[3] = PWM test enable. PWM_LEDON is now driven using the LEDSTART pin.
	7:6	Reserved	00	Must be set to zero
Revision	0	Reserved	X	This bit should be ignored
Number	7:1	REV_NUM [6:0]		Revision Number of device

Table 11 Extended Page Register Bits

RECOMMENDED EXTERNAL COMPONENTS

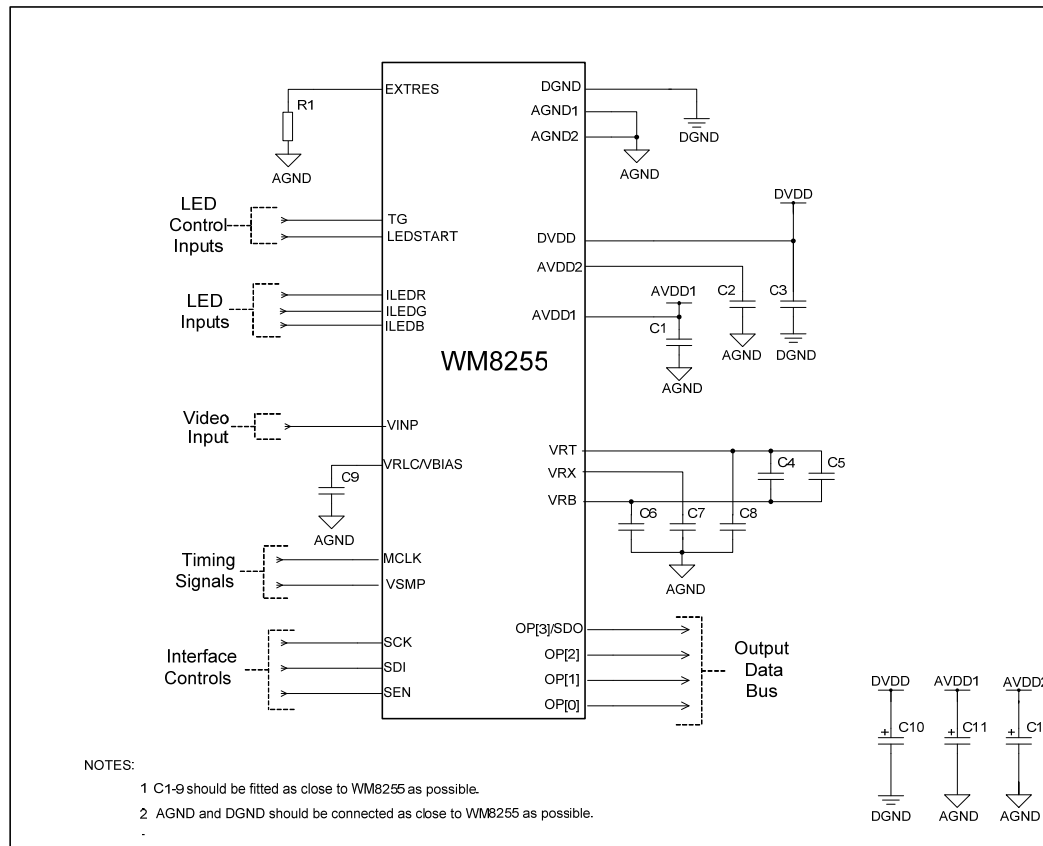
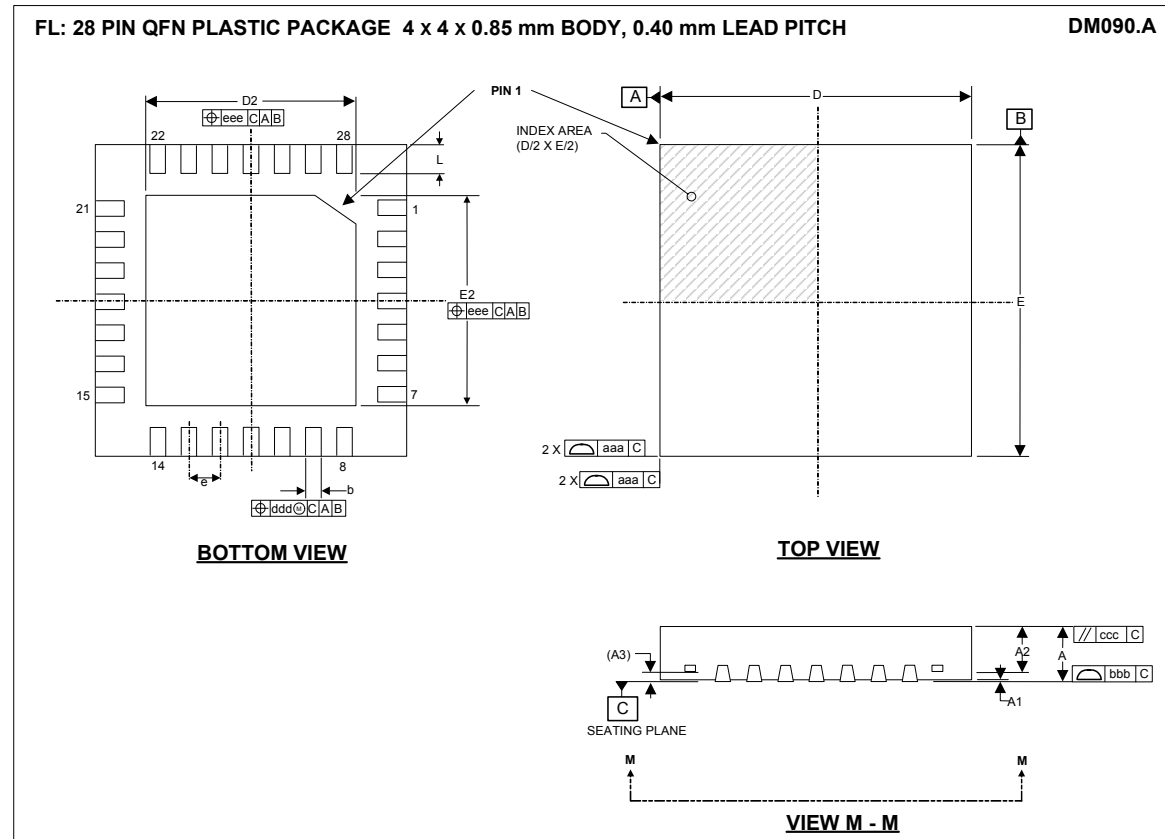

Figure 33 External Components Diagram

COMPONENT REFERENCE	SUGGESTED VALUE	DESCRIPTION
R1	13k7ohm	Resistor used for LED current maximum limit accuracy
C1	100nF	De-coupling for AVDD1
C2	100nF	De-coupling for AVDD2
C3	100nF	De-coupling for DVDD
C4	10nF	High frequency de-coupling between VRT and VRB
C5	1uF	Low frequency de-coupling between VRT and VRB
C6	100nF	De-coupling for VRB
C7	100nF	De-coupling for VRX
C8	100nF	De-coupling for VRT
C9	100nF	De-coupling for VRLC
C10	10uF	Reservoir capacitor for DVDD
C11	10uF	Reservoir capacitor for AVDD1
C12	10uF	Reservoir capacitor for AVDD2

Table 12 External Components Descriptions

PACKAGE DIMENSIONS



Symbols	Dimensions (mm)			NOTE
	MIN	NOM	MAX	
A	0.8	0.85	0.9	
A1	0	0.035	0.05	
A2	-	0.65	0.67	
A3		0.203 REF		
b	0.15	0.20	0.25	1
D		4.00 BSC		
D2	2.60	2.70	2.80	
E		4.00 BSC		
E2	2.60	2.70	2.80	
e		0.4 BSC		
L	0.30	0.35	0.40	
Tolerances of Form and Position				
aaa		0.10		
bbb		0.08		
ccc		0.10		
ddd		0.10		
eee		0.10		
REF		JEDEC, MO-220 VGGE		

NOTES:

- DIMENSION b APPLIED TO METALLIZED TERMINAL AND IS MEASURED BETWEEN 0.15 mm AND 0.30 mm FROM TERMINAL TIP.
- ALL DIMENSIONS ARE IN MILLIMETRES
- THE TERMINAL #1 IDENTIFIER AND TERMINAL NUMBERING CONVENTION SHALL CONFORM TO JESD 95-1 SPP-002.
- COPLANARITY APPLIES TO THE EXPOSED HEAT SINK SLUG AS WELL AS THE TERMINALS.
- THIS DRAWING IS SUBJECT TO CHANGE WITHOUT NOTICE.
- REFER TO APPLICATIONS NOTE WAN_0118 FOR FURTHER INFORMATION.

IMPORTANT NOTICE

Wolfson Microelectronics plc ("Wolfson") products and services are sold subject to Wolfson's terms and conditions of sale, delivery and payment supplied at the time of order acknowledgement.

Wolfson warrants performance of its products to the specifications in effect at the date of shipment. Wolfson reserves the right to make changes to its products and specifications or to discontinue any product or service without notice. Customers should therefore obtain the latest version of relevant information from Wolfson to verify that the information is current.

Testing and other quality control techniques are utilised to the extent Wolfson deems necessary to support its warranty. Specific testing of all parameters of each device is not necessarily performed unless required by law or regulation.

In order to minimise risks associated with customer applications, the customer must use adequate design and operating safeguards to minimise inherent or procedural hazards. Wolfson is not liable for applications assistance or customer product design. The customer is solely responsible for its selection and use of Wolfson products. Wolfson is not liable for such selection or use nor for use of any circuitry other than circuitry entirely embodied in a Wolfson product.

Wolfson's products are not intended for use in life support systems, appliances, nuclear systems or systems where malfunction can reasonably be expected to result in personal injury, death or severe property or environmental damage. Any use of products by the customer for such purposes is at the customer's own risk.

Wolfson does not grant any licence (express or implied) under any patent right, copyright, mask work right or other intellectual property right of Wolfson covering or relating to any combination, machine, or process in which its products or services might be or are used. Any provision or publication of any third party's products or services does not constitute Wolfson's approval, licence, warranty or endorsement thereof. Any third party trade marks contained in this document belong to the respective third party owner.

Reproduction of information from Wolfson datasheets is permissible only if reproduction is without alteration and is accompanied by all associated copyright, proprietary and other notices (including this notice) and conditions. Wolfson is not liable for any unauthorised alteration of such information or for any reliance placed thereon.

Any representations made, warranties given, and/or liabilities accepted by any person which differ from those contained in this datasheet or in Wolfson's standard terms and conditions of sale, delivery and payment are made, given and/or accepted at that person's own risk. Wolfson is not liable for any such representations, warranties or liabilities or for any reliance placed thereon by any person.

ADDRESS:

Wolfson Microelectronics plc
Westfield House
26 Westfield Road
Edinburgh
EH11 2QB
United Kingdom

Tel :: +44 (0)131 272 7000

Fax :: +44 (0)131 272 7001

Email :: sales@wolfsonmicro.com

REVISION HISTORY

DATE	REV	ORIGINATOR	CHANGES
04/04/12	4.6	JMacD	Order codes changed from WM8255SEFL and WM8255SEFL/R to WM8255CSEFL/R and WM8255CSEFL/R to reflect change to copper wire bonding.
04/04/12	4.6	JMacD	Package diagram changed to DM109.A. A1 changed from 0.9mm to 0.85mm
19/08/13	4.7	JMacD	Order codes WM8255CSEFL and WM8255CSEFL/R removed.
19/08/13	4.7	JMacD	Package diagram DM109A removed.