

## Description

The AP3125B is a current mode PWM controller which is optimized for high performance, low standby power and cost effective offline flyback converters.

The PWM switching frequency at normal operation is internally fixed (about 65kHz). In middle load, the IC will enter green mode to improve system efficiency with the help of frequency foldback. A minimum switching frequency (about 20kHz) is set to avoid the audible noise. In no load or light load, the IC will enter the burst mode to minimize standby power. Furthermore, the frequency dithering function is built-in to reduce EMI emission.

Internal slope compensation allows more stable Peak-Current Mode control over wide range of input voltage and load conditions. Internal line compensation ensures constant output power limit over entire universal line voltage range.

Comprehensive protection features are included, such as cycle-by-cycle current limit (OCP), VCC Over Voltage Protection (VOVP), internal OTP, Over Load Protection (OLP) and pins' fault protection. Built-in Brownout (BNO) and Line Over Voltage Protection (LOVP) are also integrated in AP3125B.

## Features

- Very Low Start-up Current
- Current Mode Control
- Non-audible-noise Green-mode Control
- Internal Slope Compensation
- Soft Start During Startup Process
- Frequency Fold Back for High Average Efficiency
- Secondary Winding Short Protection with FOCP
- Soft Switching for Reducing EMI
- VCC Maintain Mode
- Brownout Protection (BNO)
- Line Over Voltage Protection (LOVP)
- Useful Pin Fault Protection:
  - SENSE Pin Floating
  - SENSE Pin Short to Ground
  - FB/Opto-coupler Open/Short
- Comprehensive System Protection Feature:
  - VCC Over Voltage Protection (VOVP)
  - Over Load Protection (OLP)
- Mini Size with Packages
- Pin to Pin Compatible with AP3105NA/NV/NL/NR
- **Totally Lead-free & Fully RoHS Compliant (Notes 1 & 2)**
- **Halogen and Antimony Free. "Green" Device (Note 3)**

- Notes:
1. No purposely added lead. Fully EU Directive 2002/95/EC (RoHS) & 2011/65/EU (RoHS 2) compliant.
  2. See [http://www.diodes.com/quality/lead\\_free.html](http://www.diodes.com/quality/lead_free.html) for more information about Diodes Incorporated's definitions of Halogen- and Antimony-free, "Green" and Lead-free.
  3. Halogen- and Antimony-free "Green" products are defined as those which contain <900ppm bromine, <900ppm chlorine (<1500ppm total Br + Cl) and <1000ppm antimony compounds.

## Pin Assignments

(Top View)

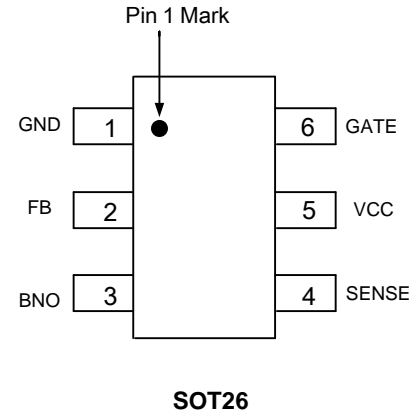

## Applications

- Switching AC-DC Adapter/Charger
- ATX/BTX Auxiliary Power
- Set-top Box (STB) Power Supply
- Open Frame Switching Power Supply

**Typical Applications Circuit**

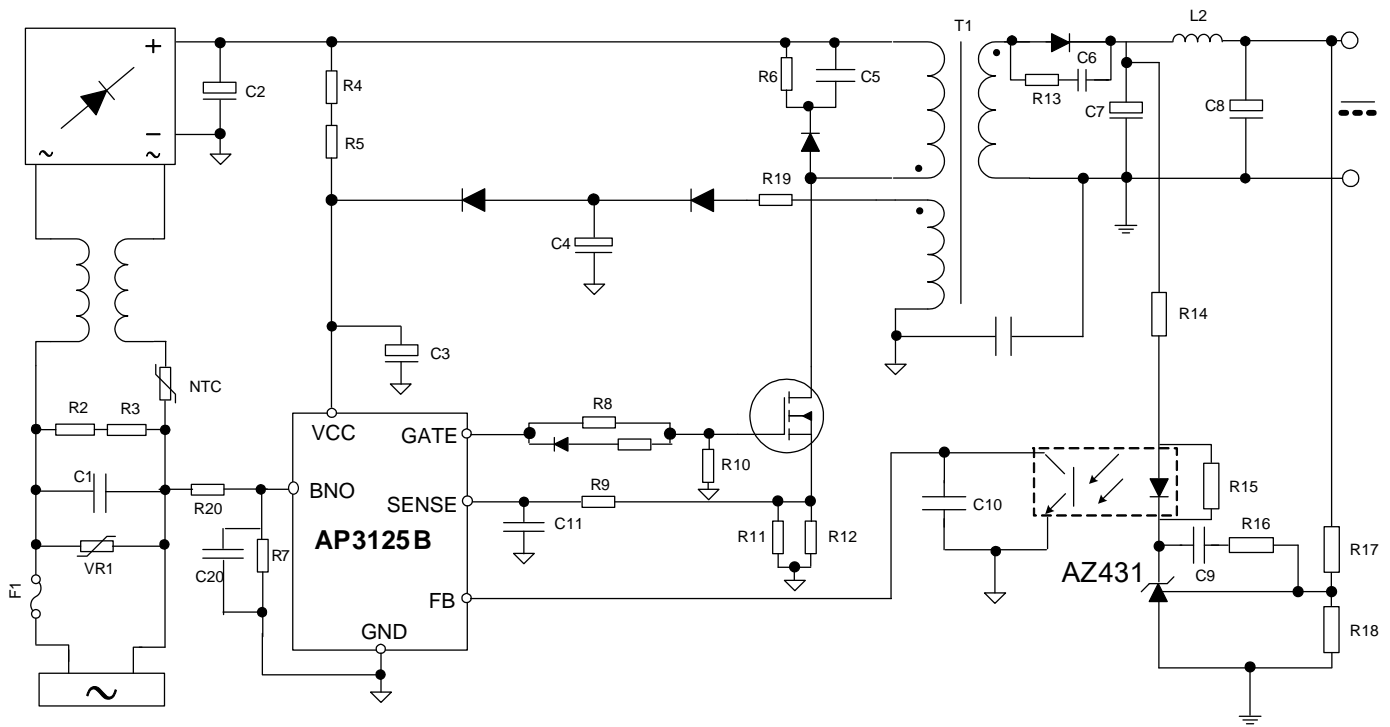

NEW PRODUCT

**Pin Descriptions**

Pin Number	Pin Name	Function
1	GND	Signal ground. Current return for driver and control circuits
2	FB	Feedback. Directly connected to the opto-coupler
3	BNO	Control brownout protection
4	SENSE	Current sense
5	VCC	Supply voltage of driver and control circuits
6	GATE	Gate driver output

**Functional Block Diagram**

NEW PRODUCT

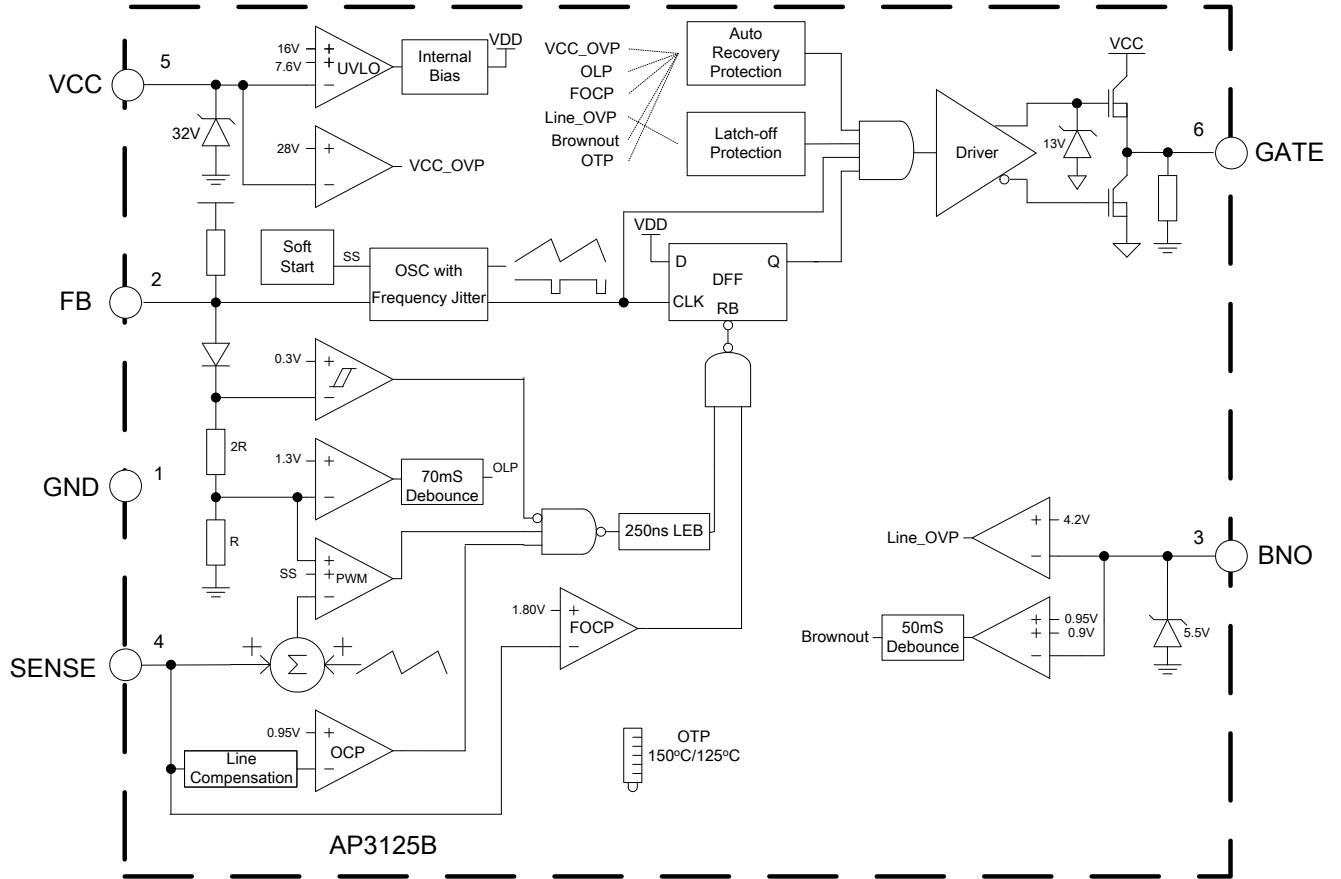

### Absolute Maximum Ratings (Note 4)

Symbol	Parameter	Rating	Unit
$V_{CC}$	Power Supply Voltage	30	V
$I_O$	Gate Output Current	350	mA
$V_{FB}, V_{SENSE}, V_{BNO}$	Input Voltage to FB, SENSE, BNO	-0.3 to 7	V
$\theta_{JA}$	Thermal Resistance (Junction to Ambient)	250	°C/W
$P_D$	Power Dissipation at $T_A < +25\text{ °C}$	500	mW
$T_J$	Operating Junction Temperature	-40 to +150	°C
$T_{STG}$	Storage Temperature Range	+150	°C
-	ESD (Human Body Model)	3000	V
-	ESD (Machine Model)	300	V

Note 4: Stresses greater than those listed under "Absolute Maximum Ratings" may cause permanent damage to the device. These are stress ratings only, and functional operation of the device at these or any other conditions beyond those indicated under "Recommended Operating Conditions" is not implied. Exposure to "Absolute Maximum Ratings" for extended periods may affect device reliability.

### Recommended Operating Conditions

Symbol	Parameter	Min	Max	Unit
$V_{CC}$	Supply Voltage	10	25	V

**Electrical Characteristics** (@T<sub>A</sub> = +25°C, V<sub>CC</sub> = 16V, unless otherwise specified.)

Symbol	Parameter	Conditions	Min	Typ	Max	Unit
<b>Supply Voltage (VCC Pin)</b>						
I <sub>STARTUP</sub>	Startup Current	–	–	1	10	μA
I <sub>CC</sub>	Operating Supply Current	V <sub>FB</sub> =0V, C <sub>L</sub> =1nF	0.5	0.7	1	mA
		V <sub>FB</sub> =3V, C <sub>L</sub> =0nF	0.6	1.2	2.0	
–	U <sub>VLO (on)</sub>	–	14.5	15.8	16.5	V
–	V <sub>CC</sub> Maintain	–	8.6	9.1	9.6	V
–	U <sub>VLO (off)</sub>	–	7.1	7.6	8.1	V
–	V <sub>CC</sub> OVP	–	27	28.5	30	V
–	V <sub>CC</sub> Clamp	I <sub>CC</sub> =5mA	31	34	–	V
<b>PWM Section/Oscillator Section</b>						
–	Maximum Duty Cycle	–	70	75	80	%
–	Oscillation Frequency	–	60	65	70	kHz
–	Green Mode Frequency	–	20	–	30	kHz
–	Frequency Temperature Stability	-20°C to +125°C (Note 5)	–	–	5	%
–	Frequency Voltage Stability	V <sub>CC</sub> =12V to 30V	–	–	3	%
–	Frequency Dithering	–	±4	±6	±8	%
<b>Current Sense Section (SENSE Pin)</b>						
V <sub>CS</sub>	Maximum SENSE Voltage	V <sub>FB</sub> =4.5V	0.9	0.95	1	V
–	FOCP Voltage	–	1.5	1.7	1.9	V
–	SENSE Shorted Protection Threshold	–	–	0.1	–	V
–	LEB Time of SENSE	–	150	250	350	ns
–	Delay to Output (Note 5)	–	–	100	–	ns
–	Soft-start Time	–	3	5	8	ms
<b>Feedback Input Section (FB Pin)</b>						
–	The Ratio of Input Voltage to Current Sense Voltage	–	2.5	3	3.5	V/V
–	Input Impedance	–	12	15	18	kΩ
–	Source Current	V <sub>FB</sub> =0V	-0.2	-0.27	-0.34	mA
–	Green Mode Threshold	–	–	2.1	–	V
–	Input Voltage for Zero Duty	–	1.3	1.55	1.8	V
<b>Output Section (GATE Pin)</b>						
–	Output Low Level	I <sub>O</sub> =20mA, V <sub>CC</sub> =12V	–	–	1	V
–	Output High Level	I <sub>O</sub> =20mA, V <sub>CC</sub> =12V	8	–	–	V
–	Output Clamping Voltage	–	11	13	15	V
–	Rising Time (Note 5)	C <sub>L</sub> =1nF, V <sub>CC</sub> =13V	–	150	250	ns
–	Falling Time (Note 5)	C <sub>L</sub> =1nF, V <sub>CC</sub> =13V	–	50	100	ns

**Electrical Characteristics** (Cont.) (@T<sub>A</sub> = +25°C, V<sub>CC</sub> = 16V, unless otherwise specified.)

Symbol	Parameter	Conditions	Min	Typ	Max	Unit
<b>Brownout Section (BNO Pin)</b>						
–	Brown-in Voltage	–	0.93	0.95	0.97	V
–	Brownout Voltage	–	0.88	0.9	0.92	V
–	Clamping Voltage	I <sub>CLAMP</sub> =1mA	–	5.5	–	V
–	Line OVP	–	4.1	4.2	4.3	V
<b>Delay Time Section</b>						
–	Delay of Short Circuit Protection	–	–	70	–	ms
–	Delay of Hiccup Protection	VCC OVP	–	5	–	Cycles
–	De-bounce Time of Brownout	–	–	50	–	ms
<b>Internal OTP Section</b>						
–	OTP Enter	–	–	+150	–	°C
–	OTP Exit	–	–	+125	–	°C

Note 5: Guaranteed by design.

**Performance Characteristics**

**Startup Voltage vs. Ambient Temperature**



**Shutdown Voltage vs. Ambient Temperature**

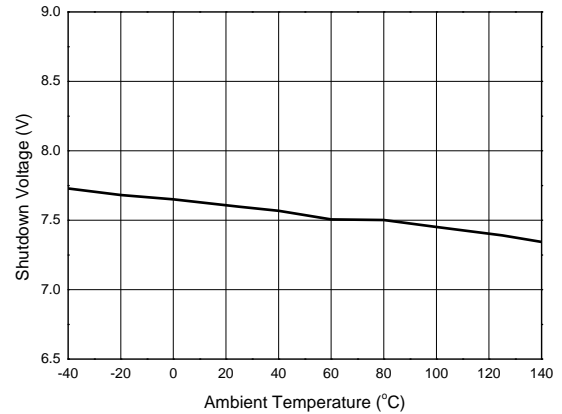

**Startup Current vs. Ambient Temperature**



**Operating Current vs. Ambient Temperature**



**BNO Utilization for Brownout**

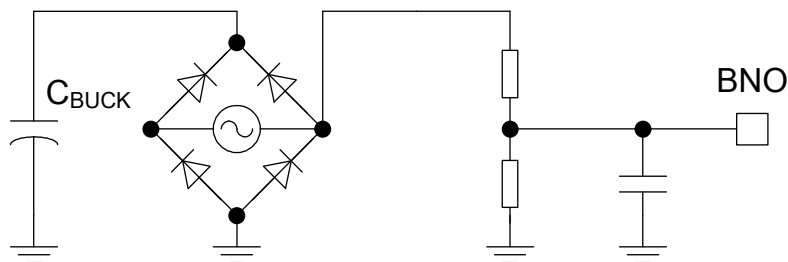

## Operation Description

The AP3125B is specifically designed for off-line AC-DC power supply used in LCD monitor, notebook adapter and battery charger applications. It offers a cost effective solution with a versatile protection function.

### Start-up Current and UVLO

The start-up current of AP3125B is optimized to realize ultra low current (1μA typical) so that VCC capacitor can be charged more quickly. The direct benefit of low start-up current is the availability of using large start-up resistor, which minimizes the resistor power loss for high voltage AC input.

An UVLO comparator is included in AP3125B to detect the voltage on VCC pin. It ensures that AP3125B can draw adequate energy from hold-up capacitor during power-on. The turn-on threshold is 16V and the turn-off threshold is 7.6V.

### Current Sense Comparator and PWM Latch

The AP3125B operates as a current mode controller, the output switch conduction is initiated by every oscillator cycle and is terminated when the peak inductor current reaches the threshold level established by the FB pin. The inductor current signal is converted to a voltage signal by inserting a reference sense resistor  $R_S$ . The inductor current under normal operating conditions is controlled by the voltage at FB pin. The relation between peak inductor current ( $I_{PK}$ ) and  $V_{FB}$  is:

$$I_{PK} = (V_{FB} - 0.8) / 3R_S$$

Moreover, FOCP with 1.8V threshold is only about 100ns delay, which can avoid some catastrophic damages such as secondary rectifier short test. Few drive cycles can alleviate the destruction range and get better protection.

### Leading-edge Blanking

A narrow spike on the leading edge of the current waveform can usually be observed when the power MOSFET is turned on. A 250ns leading-edge blank is built-in to prevent the false-triggering caused by the turn-on spike. During this period, the current limit comparator is disabled and the gate driver can not be switched off.

At the time of turning off the MOSFET, a negative undershoot (maybe larger than -0.3V) can occur on the SENSE pin. So it is strongly recommended to add a small RC filter or at least connect a resistor "R" on this pin to protect the IC (Shown as Figure 1).

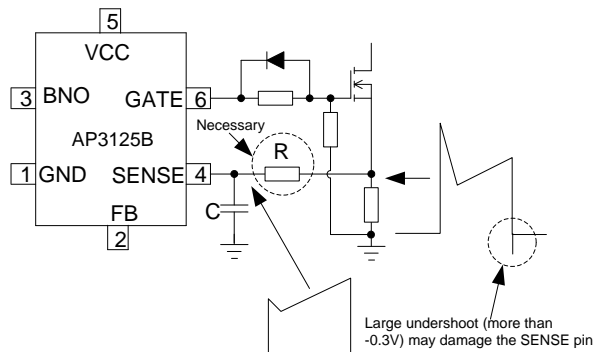

Figure 1

### Built-in Slope Compensation

It is well known that a continuous current mode SMPS may become unstable when the duty cycle exceeds 50%. The built-in slope compensation can improve the stability, so there is no need for design engineer to spend much time on that.

### FB Pin and Short Circuit Protection

This pin is normally connected to the opto-coupler and always paralleled with a capacitor for loop compensation. When the voltage at this pin is greater than 4.5V and lasts for about 70ms, the IC will enter the protection mode. For AP3125B, the system will enter hiccup mode to wait the VCC decreasing to low UVLO level, then the IC will try to restart until the failure removed. And when this voltage is less than 1.55V, the IC will stop the drive pulse immediately. Therefore, this feature can be used for short circuit protection, which makes the system immune from damage. Normally, output short makes the  $V_{FB}$  value to the maximum because the opto-coupler is cut off.

### VCC Maintain Mode

During light load or step load,  $V_{FB}$  will drop and be lower than 1.55V, thus the PWM drive signal will be stopped, and there is no more new energy transferred due to no switching. Therefore, the IC supply voltage may reduce to the shutdown threshold voltage and system may enter the unexpected restart mode. To avoid this, the AP3125B hold a so-called VCC maintain mode which can supply energy to VCC.

When VCC decreases to a setting threshold, the VCC maintain comparator will output some drive signal to make the system switch and provide a proper energy to VCC pin. The VCC maintain function will cooperate with the PWM and burst mode loop which can make the output voltage variation be within the regulation. This mode is very useful for reducing startup resistor loss and achieving a better standby performance with a low value VCC capacitor. The VCC is not easy to touch the shutdown threshold during the startup process and step load. This will also simplify the system design. The minimum VCC voltage is suggested to be designed a little higher than VCC maintain threshold thus can achieve the best balance between the standby and step load performance.

### System Protection and Pin Fault Protection

The AP3125B provides versatile system and pin fault protections. The OCP comparator realizes the cycle-by-cycle current limiting (OCP). In universal input line voltage, the IC realizes the constant over load protection (OLP). VCC over voltage protection can be applied as the primary OVP or opto-coupler broken protection. The AP3125B also has pin fault connection protection including floating and short connection. The floating pin protection includes the SENSE, FB, etc. The short pin protection includes the CTRL pin short protection. When these pins are floated or CTRL pin is shorted to ground, PWM switching will be disabled, thus protecting the power system.



## Operation Description (Cont.)

### Brownout Protection Function

To avoid potential high current stress at low line voltage, AP3125B introduces reliable brownout protection. AC line voltage information is sampled through a voltage divider network, adjusting the divider ratio to achieve expected brownout protection voltage. A typical 0.1nF capacitor is strongly recommended to parallel with BNO pin to bypass any accidental spike in AC line for preventing false trigger. When the voltage across BNO pin is higher than 0.95V and  $V_{CC}$  reaches UVLO/ON, the GATE pin will output drive signals. If the BNO voltage falls below 0.9V and lasts for 50ms, the GATE pin will

turn off and the system will enter hiccup mode until the line voltage rises over its brown-in voltage again.

### Internal OTP Protection Function

The AP3125B integrates an internal temperature sensor. It has a trigger window of +150°C enter and +125°C exit. The internal OTP protection mode is auto-recovery mode.

## Ordering Information

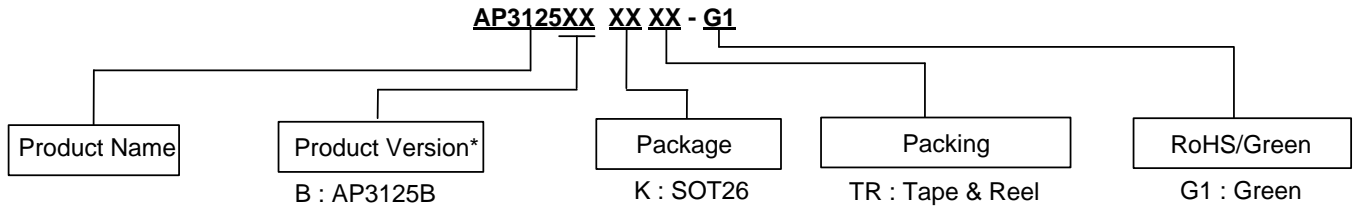

Diodes IC's Pb-free products with "G1" suffix in the part number, are RoHS compliant and green.

Package	Part Number	Marking ID	Packing
SOT26	AP3125BKTR-G1	GLV	3000/Tape & Reel

## \*Product Version Classification (with Different Protection Functions)

Product Version	Frequency	VOVP	OLP & SOCP	BNO	LOVP
AP3125B	65kHz	Auto-Recoverable	Auto-Recoverable	Auto-Recoverable	Latch

## Marking Information

(Top View)

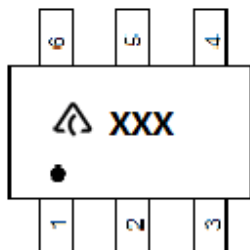

: Logo  
 XXX: Marking ID (See Ordering Information)

**Package Outline Dimensions** (All dimensions in mm(inch).)

(1) Package Type: SOT26

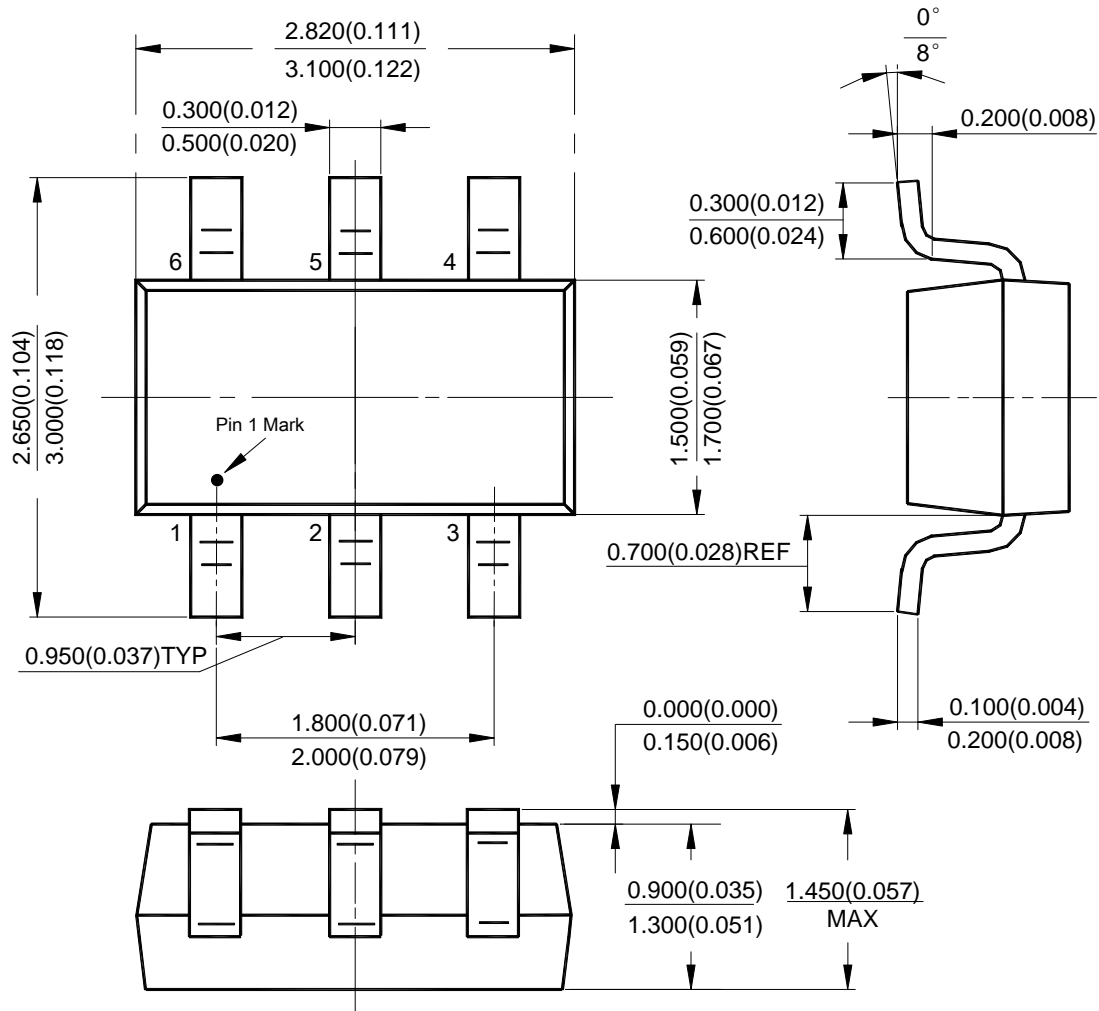

NEW PRODUCT

## Suggested Pad Layout

(1) Package Type: SOT26

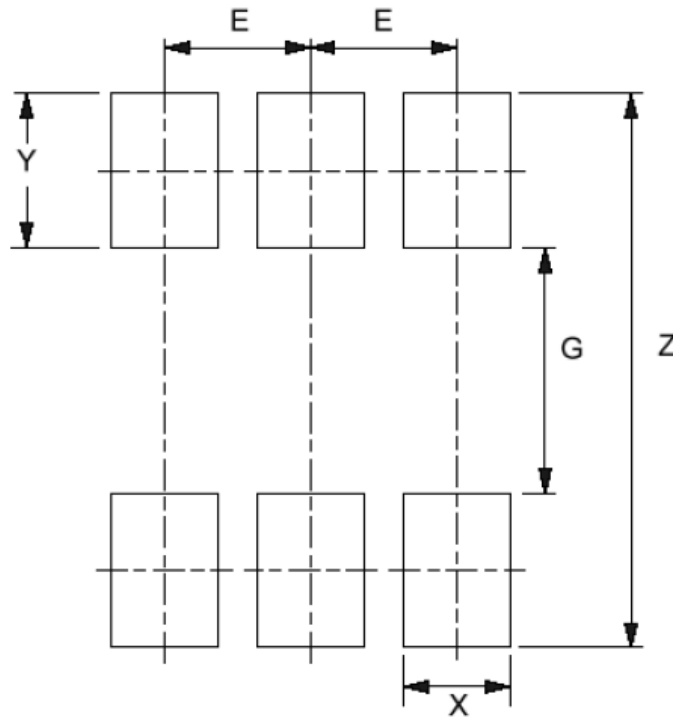

Dimensions	Z (mm)/(inch)	G (mm)/(inch)	X (mm)/(inch)	Y (mm)/(inch)	E (mm)/(inch)
Value	3.600/0.142	1.600/0.063	0.700/0.028	1.000/0.039	0.950/0.037

#### IMPORTANT NOTICE

DIODES INCORPORATED MAKES NO WARRANTY OF ANY KIND, EXPRESS OR IMPLIED, WITH REGARDS TO THIS DOCUMENT, INCLUDING, BUT NOT LIMITED TO, THE IMPLIED WARRANTIES OF MERCHANTABILITY AND FITNESS FOR A PARTICULAR PURPOSE (AND THEIR EQUIVALENTS UNDER THE LAWS OF ANY JURISDICTION).

Diodes Incorporated and its subsidiaries reserve the right to make modifications, enhancements, improvements, corrections or other changes without further notice to this document and any product described herein. Diodes Incorporated does not assume any liability arising out of the application or use of this document or any product described herein; neither does Diodes Incorporated convey any license under its patent or trademark rights, nor the rights of others. Any Customer or user of this document or products described herein in such applications shall assume all risks of such use and will agree to hold Diodes Incorporated and all the companies whose products are represented on Diodes Incorporated website, harmless against all damages.

Diodes Incorporated does not warrant or accept any liability whatsoever in respect of any products purchased through unauthorized sales channel. Should Customers purchase or use Diodes Incorporated products for any unintended or unauthorized application, Customers shall indemnify and hold Diodes Incorporated and its representatives harmless against all claims, damages, expenses, and attorney fees arising out of, directly or indirectly, any claim of personal injury or death associated with such unintended or unauthorized application.

Products described herein may be covered by one or more United States, international or foreign patents pending. Product names and markings noted herein may also be covered by one or more United States, international or foreign trademarks.

This document is written in English but may be translated into multiple languages for reference. Only the English version of this document is the final and determinative format released by Diodes Incorporated.

#### LIFE SUPPORT

Diodes Incorporated products are specifically not authorized for use as critical components in life support devices or systems without the express written approval of the Chief Executive Officer of Diodes Incorporated. As used herein:

A. Life support devices or systems are devices or systems which:

1. are intended to implant into the body, or
2. support or sustain life and whose failure to perform when properly used in accordance with instructions for use provided in the labeling can be reasonably expected to result in significant injury to the user.

B. A critical component is any component in a life support device or system whose failure to perform can be reasonably expected to cause the failure of the life support device or to affect its safety or effectiveness.

Customers represent that they have all necessary expertise in the safety and regulatory ramifications of their life support devices or systems, and acknowledge and agree that they are solely responsible for all legal, regulatory and safety-related requirements concerning their products and any use of Diodes Incorporated products in such safety-critical, life support devices or systems, notwithstanding any devices- or systems-related information or support that may be provided by Diodes Incorporated. Further, Customers must fully indemnify Diodes Incorporated and its representatives against any damages arising out of the use of Diodes Incorporated products in such safety-critical, life support devices or systems.

Copyright © 2014, Diodes Incorporated

[www.diodes.com](http://www.diodes.com)